

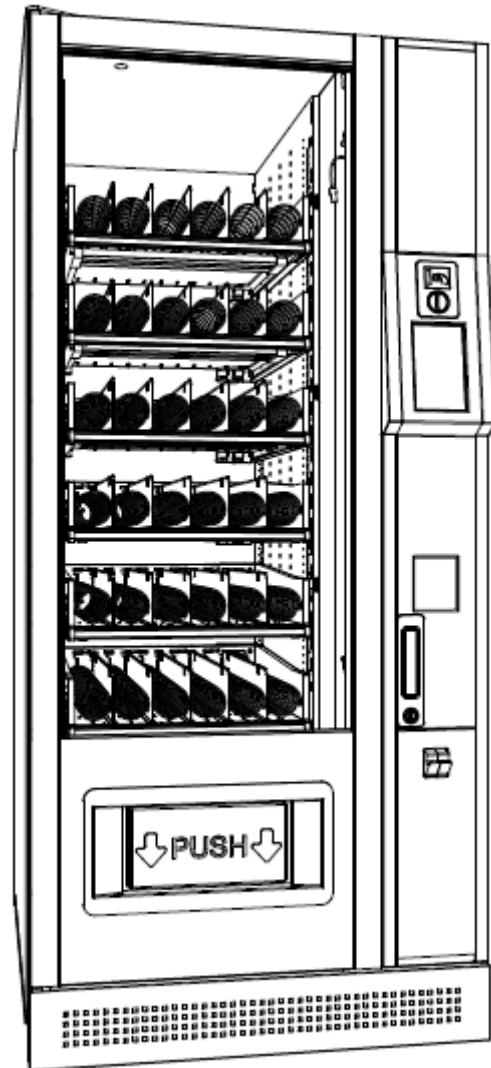

User and maintenance manual

	10 Selection	8 Selection	6 Selection
G-Snack Standard	SVE SMX	SVE SM8	SVE SM6
G-Snack Design Line	SVE SDX	SVE SD8 SVE SC8	SVE SD6 SVE SC6
G-Snack Design Line TouchScreen	SVE STX	SVE ST8	SVE ST6

— Design Line —



SandenVendo Europe S.p.A.
 Regione Cavallino,2
 15030 Coniolo (AL) - Italy
 Tel. +39 0142.335111
 Fax +39 0142.562348
 E-mail: marketing@sandenvendo.it
 website: www.sandenvendo.com

SandenVendo GmbH (SVG)

Kolberger Str.7
40599 Düsseldorf
Germany
Tel.: + 49 211 740390
Fax: + 49 211 7488541
e-mail: info@sandenvendo.de
www.sandenvendo.com

SandenVendo GmbH Italian Branch

Via Galeotto del Carretto 10
15033 Casale Monferrato (AL) – Italy
Tel.:+ 39 0142 234 220
Fax: + 39 0142 231 153
e-mail: marketing@sandenvendo.it

SandenVendo Spain Sucursal en España

Poligono Industrial la Almeda
C/. Sant Ferrán, no. 92
E-08940 Cornellà (Barcelona) - Spain
Tel. : +34 (0)93 4741555
Fax : +34 (0)93 4741842
e-mail: info@sandenvendo.es

SandenVendo Belgium Branch of SandenVendo GmbH

Avenue A. Van Oss 1 - Boîte 21
1120 Bruxelles - Belgium
Tel.: +32 (0)2 2682595
Fax :+32 (0)2 2682862
e-mail: info@sandenvendo.be

SandenVendo France Branch of SandenVendo GmbH

140 bis rue de RENNES
75006 Paris - FRANCE
Stéphane Bourdin Tel. : +33 6 59 25 87 81
Brice Passot Tel. : +33 6 38 63 67 54
SAV Jean Paul Riche Tel. : +33 6 40 30 83 17
e-mail: info@sandenvendo.fr

1 GENERAL ADVERTISEMENT	3
1.1 Purpose of this manual	3
1.2 To whom this manual is addressed.....	4
1.4 Manufacturer	6
1.5 Service centers.....	6
1.6 Warranty.....	7
1.6 General safety warnings.....	9
1.7 Security symbols and Pictograms.....	11
2 VENDING MACHINE IDENTIFICATION.....	14
2.1 Identification Plate	14
2.2 General Description.....	15
2.2.1 Models Name	15
2.3 Differences between models.....	16
2.4 Technical features	18
2.4.1 Electrical features models 230V.....	18
2.4.2 Standard Refrigerant System [R-134a].....	18
2.4.3 Refrigerant System CO2	19
2.4.4 Hydrocarbons Refrigerant System [R290].....	19
2.4.5 Technical features for Models 115V Standard Refrigerant System	20
2.5 Description of components	21
2.5.1 Outdoor External Components.....	22
2.6 Referral programming manual	22
3 TRANSPORT, STORAGE AND INSTALLATION	23
3.1 Transport and Storage.....	23
3.2 Unpacking	24
3.2.1 Removing the wooden bases	25
3.2.2 Installation / Removal Lower Grid	25
3.2.3 Supplied Accessories	25
3.3 Installation	26
3.3.1 Installation environment features	26
3.3.2 Placement.....	27
3.3.2.1 Installation spaces and spaces of use	28
3.3.3 Connection to power mains	29
3.3.4 Stability	30
3.3.5 Installing the coin mechanism	31
3.3.5.1 Coinmech Connection MDB / Executive.....	32
3.3.6 Selection labels installation	32
3.4 How to split the model with 6 / 8 selection	33
4 USE AND OPERATION OF THE VENDING MACHINE.....	35
4.1 Proper Use	35
4.1.2 Distribution capacity	36
4.2 Access to internal parts	37
4.2.1 Safety devices	37
4.2.2 Board	38
4.2.2.1 SVE01 Board [only with SVE01 control board].....	38
4.2.2.2 SVE02 Board [only with SVE01 control board].....	38
4.2.2.3 Relay Board [only with SVE01 control board].....	38
4.2.2.4 Elevator Motor Board (Optional).....	39
4.2.2.5 SVBA E-Labeling Board (Optional).....	39
4.2.2.6 Control boardEMA0206 [only with Linux control board].....	39
4.2.2.7 Interface board EMA0212 [only with Linux control board]	40
4.2.2.8 Board EMA0240 (Optional) [only with Linux control board]	40
4.2.2.9 Board EMA0226 [only with Linux control board].....	40
4.2.3 Products Charging.....	41
4.2.3.1 Configuration of the vending machine for 2 temperatures	43
4.2.4 Shelf Adjustments.....	44
4.2.4.1 Shelf "Spiral Ø120" (Optional).....	45
4.2.4.2 Shelf with E-Label (optional).....	46
4.2.4.3 "Belt" Vending System	47
4.2.4.4 "Rotary" Vending System.....	50
4.2.4.5 Spirals.....	54

4.2.4.6 Kit Sandwich.....	55
4.2.4.7 Kit Baguette.....	55
4.2.5 Shelf Extraction / Removal.....	56
4.2.5.1 Shelf guide.....	56
4.2.5.2 How to measure heights between shelf.....	57
4.2.5.3 Assembly / Disassembly of Shelf Guides.....	57
4.2.6 Configuration of the vending machine for 2 temperatures.....	60
4.2.7 Elevator (optional).....	61
4.2.8 Motorized Locking for Delivery Eyelet (optional).....	62
4.2.8 Refrigerant System Operation.....	63
4.2.8.1 Description and function of Control Unit EASY CAREL.....	63
4.2.8.2 Control Unit CAREL ir33.....	66
5 MAINTENANCE.....	69
5.1 Warnings.....	69
5.2 Recommended cleaning products.....	70
5.3 Cleaning safety devices.....	70
5.4 Preventive maintenance.....	70
5.5 Cleaning operations.....	71
5.5.1 Daily Cleaning.....	71
5.5.2 Weekly Cleaning.....	71
5.5.3 Monthly Cleaning.....	71
5.5.4 Yearly Cleaning.....	72
5.6 Assembly / Disassembly for Maintenance.....	72
5.6.1 LED Replacing.....	72
5.6.2 Door Gasket Replacement.....	72
5.6.3 Spiral replacement.....	73
6 TROUBLESHOOTING.....	74
6.1 Door Errors.....	74
6.2 Cabinet Errors.....	74
6.3 Payment Device Errors.....	75
6.4 Refrigerant System Errors.....	77
6.5 Shelf Errors.....	80
7 OUT OF ORDER OPERATION.....	81
7.1 Disposal.....	81
7.2 Person in charge of disposal.....	81
7.3 Sanctions.....	81



1 General Advertisement

1.1 Purpose of this manual

 Before proceeding to install and use the vending machine, it is necessary to read the contents of this manual.

This manual is an integral part of the machine and must therefore be kept intact and available to hand for the machine's entire productive life.

Any other document sent by SandenVendo is to be attached to the manual to form a complete dossier of the automatic vending machine.

  **Caution:** failure to follow the instructions contained in this manual may involve damages to the machine and/or personnel.

 Should this manual be **lost or damaged**, you may request a copy from the manufacturer: please enclose the serial number of your vending machine with your request.

1.2 To whom this manual is addressed

The manual contains the correct procedures for the *loading, use, routine / special maintenance and installation* of the Vending Machine.

This manual is addressed to those persons in charge of loading, cleaning and routine maintenance of the machine (**Filler**), to the final user of the vending machine (**User**) and to those persons in charge of installation, adjustment, special maintenance of the vending machine (**Maintenance Engineer / Skilled technician**).

User

This appliance can be used by children aged from 8 years and above and persons with reduced physical, sensory or mental capabilities or lack of experience and knowledge if they have been given supervision or instruction concerning use of the appliance in a safe way and understand the hazards involved.

Children shall not play with the appliance.

Cleaning and user maintenance shall not be made by children without supervision.

Operator

The intervention of the operator on the vending machines is only intended for the loading and routine cleaning operations to be carried out in accessible areas with the sole use of the door opening key, and without the use of other tools.

Maintenance Engineer / Skilled technician

The intervention of the maintenance engineer is required for all operations that require the use of tools for access to potentially hazardous areas, the installation of the vending machine, the start-up and the programming of the functions.

 The maintenance technician must be previously trained and instructed on the interventions to be carried out on the vending machine and limit them to what is within his competence.

It is the responsibility of the purchaser to make sure that the maintenance personnel are trained and aware of all the information and instructions indicated in the manual.

1.4 Manufacturer

SandenVendo Europe in Europe has been making significant advancements in the vending industry for many decades and is a powerful partner for excellence in quality, reliability and service.

SandenVendo Europe are a “one-stop shop supplier”, offering a wide variety of vending equipment for hot and cold beverages, snacks and ice cream, but also related products such as sophisticated payment systems and premium coolers.

1.5 Service centers

Any technical problems that may occur can be resolved by consulting this manual; in the event of anomalies or malfunctions that cannot be resolved, contact the Service Centres at the numbers shown on the inside cover.

 In case of a call it is good to know how to indicate the data reported on the vending machine serial plate.

1.6 Warranty

The Warranty on the Vending Machine components, starting from the date shown on the delivery note, is for 12 months.

The warranty includes exclusively the parts replaced, with labour excluded.

Shipping cost of machines, defective parts and spare parts are always at the customer's expense.

The Warranty does not include, damages to the vending machine caused by:

- Transport and/or handling
- Operator errors
- Lack of maintenance as explained in this manual
- Failures and/or breakages not due to malfunction of the vending machine
- Damage which may be caused, directly or indirectly, by persons, things or animals
- Damage deriving from labour linked with the installation, connection to the main supplies.
- Improper use of the machine.

The manufacturer's responsibility is confined to the correct use of the machine, in the limits indicated in this manual.

"SandenVendo Europe S.p.A" declines all responsibility for any damages caused to persons and/or things as the result of:

- Incorrect installation
- Use of unoriginal spare parts
- Execution of changes unforeseen/unauthorized by the manufacturer
- Improper use of the machine
- Connection to inadequate supply systems and not in conformity with the regulations in force

1.6 General safety warnings

-  ▪ Carefully **read the manual** before starting or loading the vending machine
- The vending machine is constructed in a workmanlike manner. Its service life, electrical and mechanical reliability will be more efficient if it will be used correctly and regular maintenance will be carried out.
- This machine is not suitable for outside installation.
- This machine is not suitable for installation in areas where water jets are used.
- Protect the vending machine against weather conditions.
- Never position the vending machine in direct sunlight.
- To prevent hazards due to machine instability, secure the machine according to the instructions.
- Install the appliance so that the electrical plug can be easily accessed afterwards.
- The use of adapters, multiple sockets and/or extensions is forbidden.
- Use a differentiated protection system.
- If the power cable is damaged, it must be replaced by the manufacturer or by one of its technical support personnel or by a qualified electrician.

- Only maintenance technicians should remove the protective covers.
- Always read the programming manual before operating the electronic board settings
- Use only spare parts authorized by the manufacturer
- **WARNING:** Keep clear of obstruction all ventilation openings in the appliance enclosure or in the structure for building-in.
- **WARNING:** Do not damage the refrigerant circuit.
- **WARNING:** In order to reduce flammability hazards the installation of this appliance must only be carried out by a suitably qualified person.
- Original instruction in Italy.

The pictures and illustrations in this document are only indicative. **SandenVendo Europe S.p.A.** recalls that the technical and performance of products can change without notice.







“**SandenVendo Europe S.p.A.**” reserves the right of making changes on their vending machines without any advice; moreover they declare that the vendors listed in this manual are in conformity with the following directives: **2006/42/CE** (EC markings) and **2004/1935/CE**.













“**SandenVendo Europe S.p.A.**” assumes no liability for the correctness of the contents or damages caused by using this manual.

“**SandenVendo Europe S.p.A.**” reserves the right to make changes to this manual without prior notice.

1.7 Security symbols and Pictograms

In the manual and/or on the machine, hazardous areas are shown with signs, plates, symbols and icons that indicate danger or an obligation in each case.

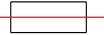
Description	Pictogram / Secure Symbol
Indicates information regarding personnel safety and machine integrity.	
Compulsory for all personnel involved	
Compulsory for all personnel involved to wear protective gloves during maintenance of the vending machine	
Compulsory for all personnel involved to protective clothing during maintenance.	
Additional information is given.	
Before carrying out this operation, refer to the Instruction Manual.	

Description	Pictogram / Secure Symbol					
In case of special operations and/or anomalies, a particular mechanical adjustment and/or electrical setting may be required.						
Indicates a warning, failure to comply may involve damage to the vending machine.						
Danger Indication of mains voltage.						
Danger Indication of the presence of cutting hazard.						
Symbol ISO 7010W021 Warning Risk of fire / flammable materials						
Warning Danger Compulsory Indicates the danger of electric shocks and mechanical risks.	 					
Caution The vending machine must be fitted with a grounding system.	<table border="1" style="width: 100%; text-align: center; font-size: small;"> <tr> <td style="width: 15%;">WARNING This vendor must be properly grounded</td> <td style="width: 15%;">ACHTUNG Dieses Gerät muß ordnungsgemäß geerdet werden</td> <td style="width: 15%;">ATTENTION Le distributeur connecté à la terre</td> <td style="width: 15%;">ATENCIÓN La máquina debe estar correctamente conectada a tierra</td> <td style="width: 15%;">ATTENZIONE Il distributore deve essere collegato a terra</td> </tr> </table>	WARNING This vendor must be properly grounded	ACHTUNG Dieses Gerät muß ordnungsgemäß geerdet werden	ATTENTION Le distributeur connecté à la terre	ATENCIÓN La máquina debe estar correctamente conectada a tierra	ATTENZIONE Il distributore deve essere collegato a terra
WARNING This vendor must be properly grounded	ACHTUNG Dieses Gerät muß ordnungsgemäß geerdet werden	ATTENTION Le distributeur connecté à la terre	ATENCIÓN La máquina debe estar correctamente conectada a tierra	ATTENZIONE Il distributore deve essere collegato a terra		
System contains refrigerant under high pressure. Do not tamper with the system. It must be serviced by qualified persons only.						
Caution Hazardous Area pay extreme care whilst operating the vend mechanisms	 					
Fuse symbol.						
Fuse type and state indicator.	<div style="display: flex; align-items: center; justify-content: center;"> <div style="border: 1px solid black; padding: 2px; margin: 0 5px;">F10A/250V</div> & <div style="border: 1px solid black; padding: 2px; margin: 0 5px;">F1A</div> </div>					
"Power Switch" button presence indicator	<div style="border: 1px solid black; padding: 5px; text-align: center;"> POWER SWITCH INTERRUPTORE GENERALE </div>					
Ground connection indicator.						
ON.						
OFF.	○					

Description	Pictogram / Secure Symbol
-------------	---------------------------

Identification Plate

Vending machine identification and main technical data

Manufactured by SandenVendo Europe S.p.A.			
Regione Cavallino 2 - 15030 Coniolo (AL) Italy			
MOD. SVE		SN	
MAX _____ A _____ V~ _____ Hz	☀️ MAX _____ W NOMINAL POWER _____ W		
REFRIGERANT _____ Kg GWP _____		T eq. CO2: _____ F1 _____ F2 _____	
The fluorinated greenhouse gases are contained in hermetically sealed equipment Equipment contains fluorinated greenhouse gases			
CL _____ °C	HR _____ %	C.F.C. FREE	
		CYCLOPENTANE	
RoHS CONFORME		Made in Italy	

Equipment only suitable for internal use indicator.



Recycling this product goes toward reducing the need of new materials and the accumulation of waste.



Recycling

Lo smaltitore al ricevimento di un'apparecchiatura con indicato il simbolo del cassone barrato ha l'obbligo, prima di smaltirla, di selezionare i rifiuti **RAEE** e di renderli eventualmente disponibili ad un eventuale recupero.



Final inspection certificate.

FINAL INSPECTION CHECK			
INSULATION TESTED	<input type="checkbox"/>	H.POT. TESTED	<input type="checkbox"/>
COOLING UNIT TESTED	<input type="checkbox"/>	MAIN BOARD SET-UP AND TESTED	<input type="checkbox"/>
VEND MECHANISM TESTED	<input type="checkbox"/>	LIGHTS WORKING	<input type="checkbox"/>
SAFETY CUT-OUT SWITCH TESTED	<input type="checkbox"/>	ALL DOORS CHECKED FOR PROPER CLOSING	<input type="checkbox"/>
MACHINE CLEAN	<input type="checkbox"/>	FINAL ACCEPTANCE	<input type="checkbox"/>

European Standard EN 50597 Plate

Energy consumption category of vending machines according to the normative.

European Standard EN 50597	
CATEGORY	MACHINE TYPE
1	Refrigerated closed fronted can and bottle machines where the products are held in stacks
2	Refrigerated glass fronted can and bottle, confectionery & snack machines
3	Refrigerated glass fronted machine entirely for perishable food stuffs
4	Refrigerated dual-temperature glass fronted machines

2 Vending Machine Identification

2.1 Identification Plate

Each SandenVendo vending machine is identified by a model name and a specific serial number, which can be found on the plate, located on the outside on the back of the vending machine and inside above the drawer.

The plate is the only one recognized by the manufacturer as the vending machine identification and contains all the data that allow the manufacturer to provide any type of technical information and to facilitate the management of spare parts.

The following data are shown on the plate:

The identification plate contains the following information:

- Name of the manufacturer, Address and Logo:** Manufactured by SandenVendo Europe S.p.A. Regione Cavallino 2 - 15030 Coniolo (AL) Italy. Logo: Vendo SANDEN.
- Model:** MOD. SVE
- Serial Number:** SN
- Supply voltage:** MAX _____ A _____ V~
- Maximum current draw:** _____ A
- Power frequency:** _____ Hz
- Electrical power absorbed:** NOMINAL POWER _____ W
- Max power of the lamp used:** _____ W
- Global warming potential:** REFRIGERANT _____ Kg GWP _____
- GWP value expressed in equivalent tons of CO²:** T eq. CO₂: _____
- Fuses:** F1 _____ F2 _____
- Type and quantity of refrigerant gas:** _____
- Climate class:** CL. _____ °C
- Relative humidity:** HR _____ %
- Conformity marking:** CE, RoHS CONFORME, and other regulatory symbols.

i An identical plate is placed above the cooling system only with the data concerning the system itself.



Attention!

It is absolutely forbidden to tamper or modify the data plate.



Important!

For any request to the service centers, always refer to this plate, indicating the specific data printed on it.

2.2 General Description

2.2.1 Models Name

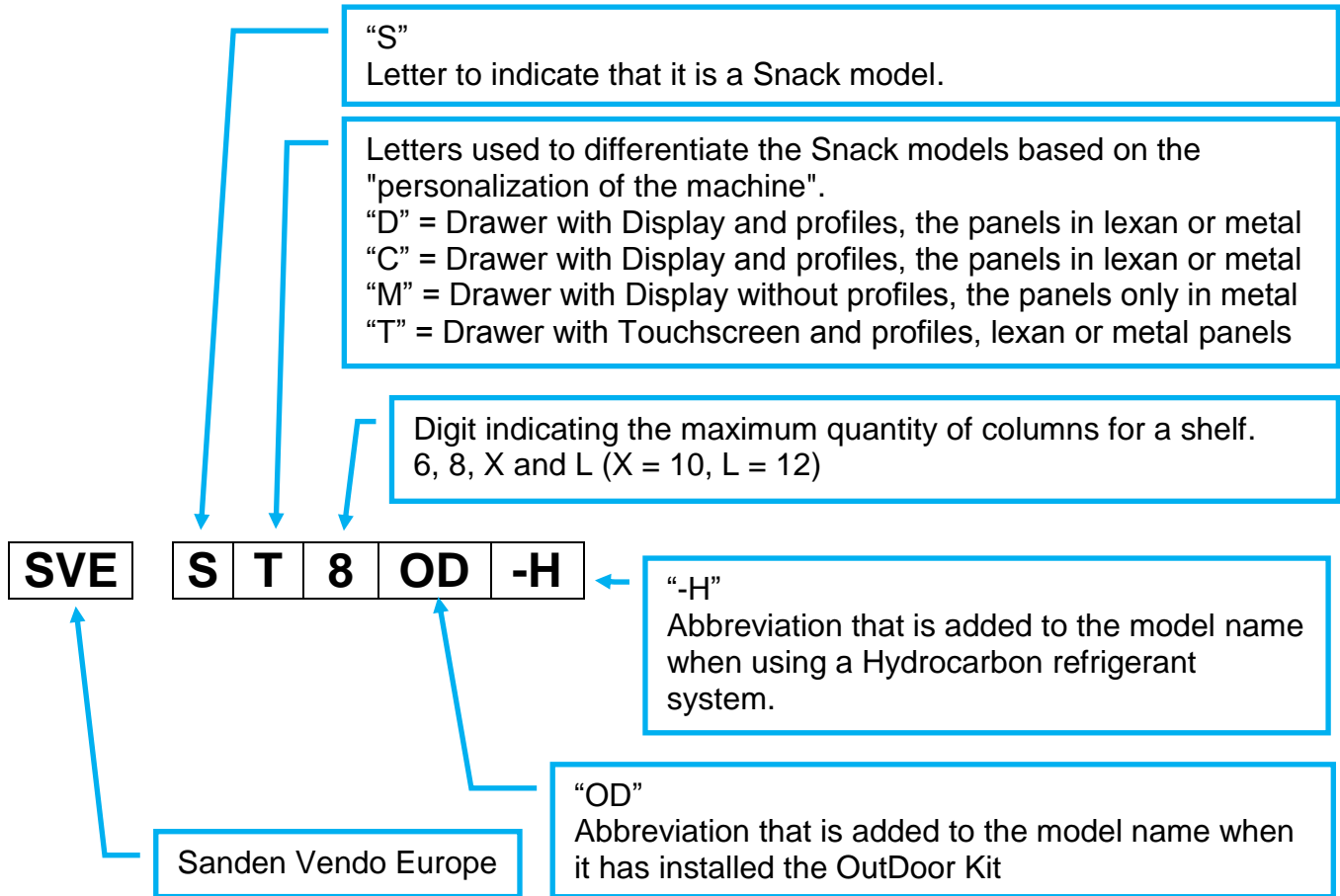

	Model			
	12 Selection*	10 Selection	8 Selection	6 Selection**
G-Snack Standard	SML SML-H SML0D SML0D-H	SMX SMX-H SMX0D SMX0D-H	SM8 SM8-H SM80D SM80D-H	SM6 SM60D
G-Snack Design Line	SDL SDL-H SDLOD SDLOD-H	SDX SDX-H SDX0D SDX0D-H	SD8 SD8-H SD80D SD80D-H	SD6 SD60D
			SC8 SC8-H SC80D SC80D-H	SC6 SC60D
G-Snack Design Line TouchScreen		STX STX-H STX0D STX0D-H	ST8 ST8-H ST80D ST80D-H	ST6 ST60D

* The model with 12 selections has a special manual P / N ° 415367.

** The Hydrocarbon version is not available for the 6 selection models.

2.3 Differences between models

The vending machine line **G-Snack Design Line** is composed by many models that have the following differences:

Model	Number of selection for each shelf	Modular Cabinet	Drawer Panel		Drawer Profiles	Display	Touch Screen	Control Board
			in Lexan	in Metal				
SDX	10		X	X	X	X		SVE01
SD8	8		X	X	X	X		SVE01
SD6	6		X	X	X	X		SVE01
SC8	8	X	X	X	X	X		SVE01
SC6	6	X	X	X	X	X		SVE01
SMX	10			X		X		SVE01
SM8	8	X		X		X		SVE01
SM6	6	X		X		X		SVE01
STX	10		X	X	X		X	Linux
ST8	8	X	X	X	X		X	Linux
ST6	6	X	X	X	X		X	Linux

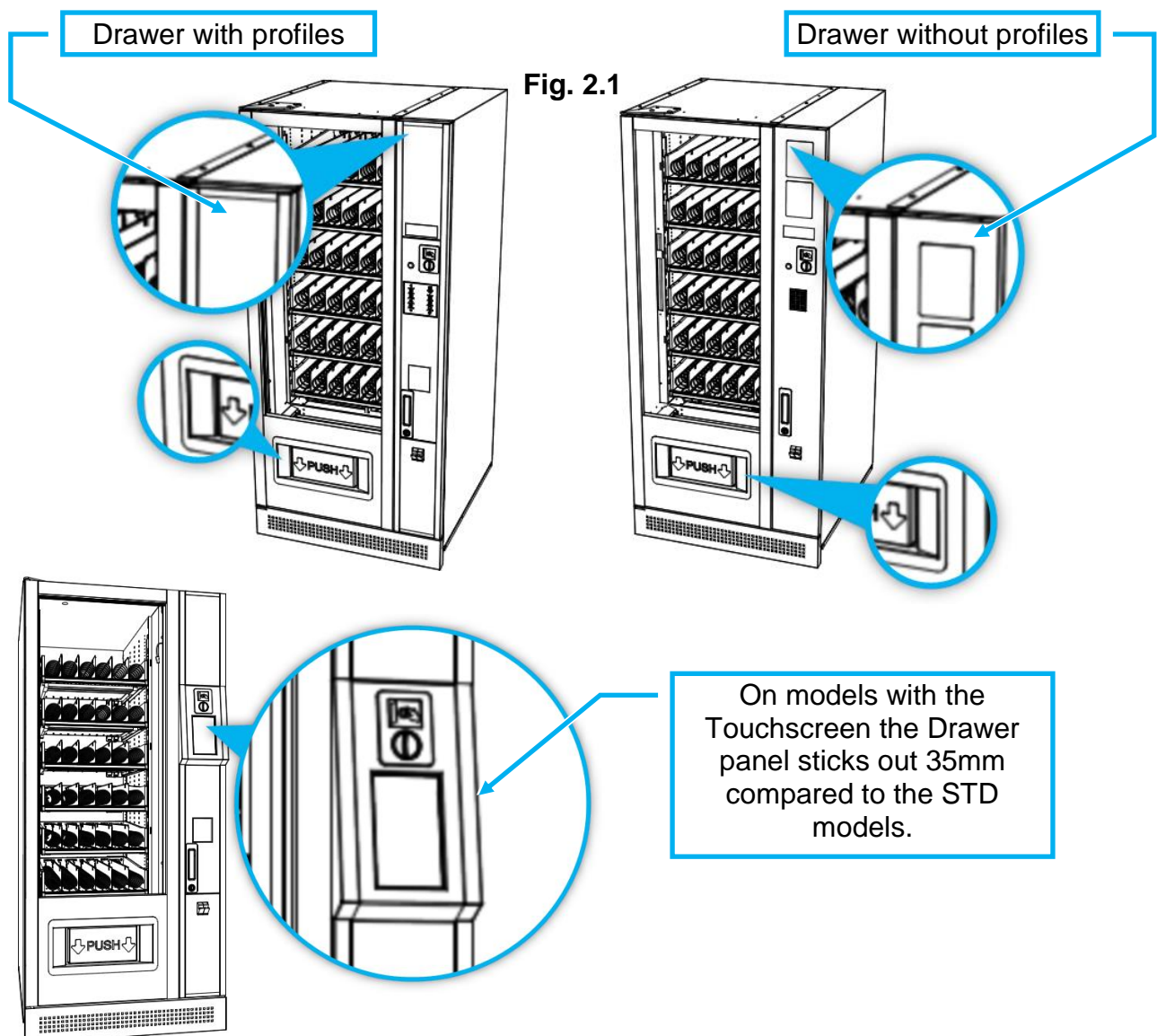

Dimensions	SDX SMX	STX	SD8 - SC8 SM8	ST8	SD6 - SC6 SM6	ST6
Height (A)	1830 mm		1830 mm		1830 mm	
Width (B)	1125 mm		980 mm		830 mm	
Cabinet Width (D)*	///		780 mm		630 mm	
Drawer Width (E)*	///		200 mm		200 mm	
Depth (C)**	845 mm	880 mm	845 mm	880 mm	845 mm	880 mm
Weight	340 Kg		310 Kg		275 Kg	

* The SDX, SMX, STX, SD8 and SD6 models do not have a modular cabinet.

** Touchscreen models are 35mm deeper.

Fig. 2.2

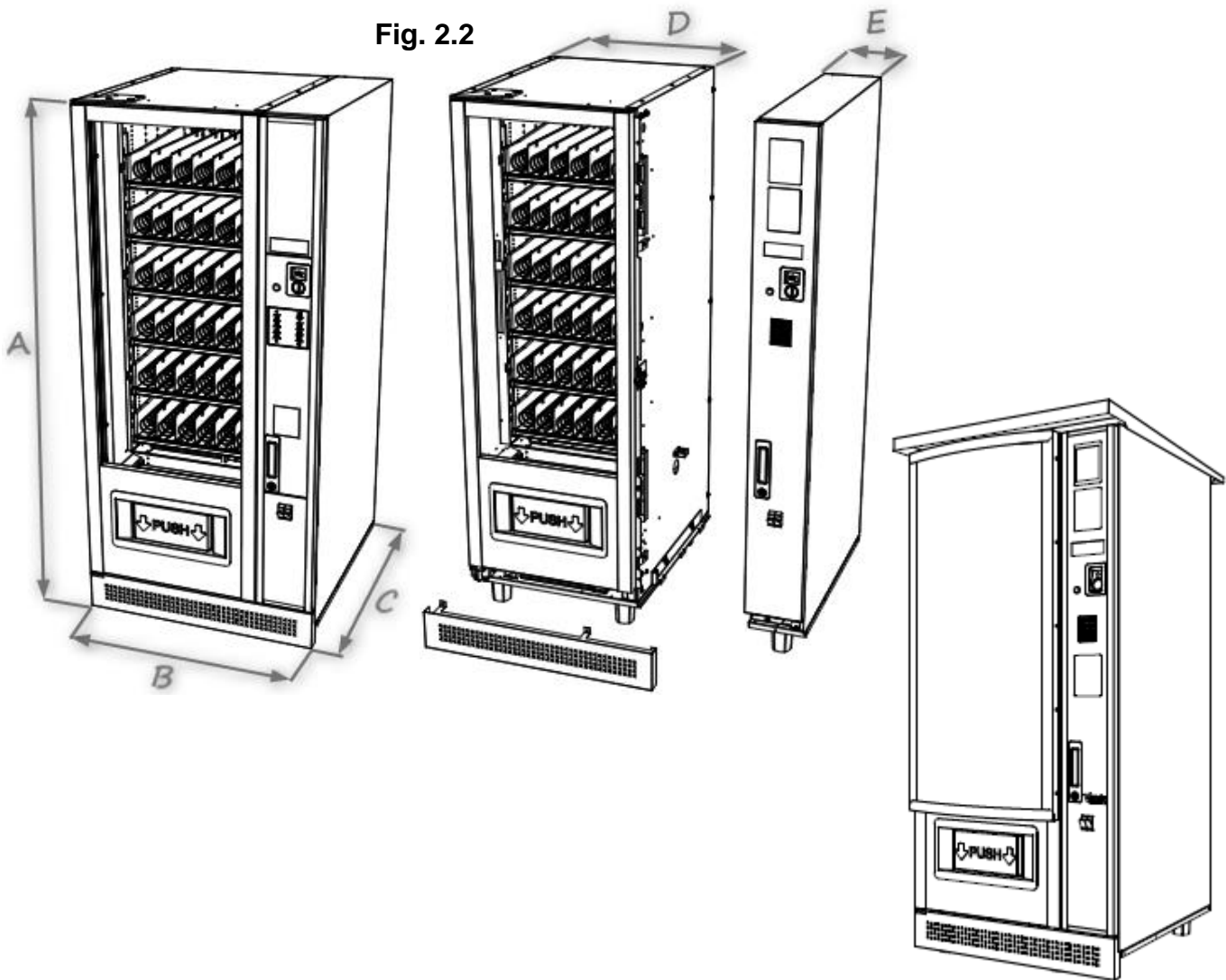

Dimensions	SDXOD - SMXOD	SD8OD SC8OD - SM8OD	SD6OD SC6OD - SM6OD
Height (A)	1872 mm	1872 mm	1872 mm
Width (B)	1162 mm	1015 mm	869 mm
Depth (C)	1010 mm	1010 mm	1010 mm
Weight	365 Kg	335 Kg	300 Kg

2.4 Technical features

Display	VFD (Vacuum Fluorescent Graphic Display) Area Display 115 x 29mm
Touch Screen (STX, ST8 e ST6)	Touch Screen 7" Capacitive
Climate class	ST (+18°C up to + 38°C)
Noise level	< 70 dB(A)
Electronic control	MDB
Payment system protocol	MDB / Executive

European Standard EN 50597	
CATEGORY	MACHINE TYPE
1	Refrigerated closed fronted can and bottle machines where the products are held in stacks
2	Refrigerated glass fronted can and bottle, confectionery & snack machines
3	Refrigerated glass fronted machine entirely for perishable food stuffs
4	Refrigerated dual-temperature glass fronted machines

According to the customization the models **G-Snack Design Line** can be included in 3 different categories of electrical consumption defined by the EN 50597 standards.

2 Refrigerated glass fronted can and bottle, confectionery & snack machines.
Maximum shelf configuration 7, set-point recommended 6°C.

3 Refrigerated glass fronted machines entirely for perishable foodstuffs.
Maximum shelf configuration 6, set-point recommended 0.5°C.

4 Refrigerated dual-temperature glass fronted machines.
Maximum shelf configuration 6, 3 shelf for perishable foodstuff and 3 shelf for not perishable foodstuff. Set-point recommended 0.5°C.

2.4.1 Electrical features models 230V

Power supply	Model with 10 / 8 Selection	Model with 6 Selection
Nominal voltage	230Vac	
Nominal frequency	50 / 60 Hz	
Max. power consumption	600 W	550 W
Fuses	F1-T10A F2-T8A	

2.4.2 Standard Refrigerant System [R-134a]

Refrigeration unit	
Compressor	12.11 cm ³
Expansion	Direct with capillary tube
Cooling system	Forced air with evaporator 2 fans
Refrigerant type	* R-134a
Refrigerant charge	1430
High Pressure	0,190 kg
Low Pressure	0,272
Adjustable temperature range	+1°C up to +25°C

* Equipment contains fluorinated greenhouse gases.

The fluorinated greenhouse gases are contained in hermetically sealed equipment.

2.4.3 Refrigerant System CO2

Refrigeration unit	
Compressor	1.75 cm ³
Expansion	Direct with capillary tube
Cooling system	Forced air with evaporator 2 fans
Refrigerant type	R-744
Refrigerant charge	0,295 Kg
High Pressure	11 MPa
Low Pressure	2.5 MPa
Adjustable temperature range	+1°C up to +25°C

2.4.4 Hydrocarbons Refrigerant System [R290]

The model that have installed the R290 refrigerant Gas have the letter "H" after the name of the model.

This type of refrigerant system is not available for 6 selection models.

Refrigeration unit	
Compressor	8,77 cm ³
Expansion	Direct with capillary tube
Cooling system	Forced air with evaporator 2 fans
Refrigerant type	R-290
GWP	3
Refrigerant charge	0,066 Kg
T e CO2	0,000198
Adjustable temperature range	+1°C up to +25°C



**Equipment contains flammable gases.*

The flammable gases are contained in hermetically sealed equipment conform at IEC 60335-2-89 norms

WARNING: Keep clear of obstruction all ventilation openings in the appliance enclosure or in the structure for building-in.

WARNING: Do not damage the refrigerant circuit.

WARNING: In order to reduce flammability hazards the installation of this appliance must only be carried out by a suitably qualified person.

WARNING: Don't use electrical and mechanical device, unless they are of the type recommended by the manufacturer.

2.4.5 Technical features for Models 115V Standard Refrigerant System

Table valid for UL version of SDX, SMX and SM8 models.

Power supply	
Nominal voltage	115Vac
Nominal frequency	60 Hz
Max. power consumption	650 W
Fuses	F1-T16A ~ F2-T8A
Refrigeration unit	
Compressor	9.99 cm ³
Expansion	Direct with capillary tube
Cooling system	Forced air with evaporator 2 fans
Refrigerant type	* R-134a
GWP	1430
Refrigerant charge	0,190 kg
T e CO ₂	0,272
Adjustable temperature range	+1°C up to +25°C
Climate class	ST (+18°C up to + 38°C)
Noise level	< 70 dB(A)
Electronic control	MDB
Payment system protocol	MDB / Executive

* *Equipment contains fluorinated greenhouse gases.*

The fluorinated greenhouse gases are contained in hermetically sealed equipment.

2.5 Description of components

1. Drawer Panel
2. Display Lexan Panel
3. Display
4. Coin Insert
5. Coin Return Push-Button
6. Keyboard
7. Plug
8. Selection Panel
9. Door Lock
10. Coin Return
11. Coin Return Lexan Panel
12. Lower Grid
13. Delivery Eyelet
14. Snack Mechanism
15. Drawer
16. Drawer Switch
17. Control Board
18. Coins Acceptance Device
19. LED Lighting
20. Coin Box
21. Box Transformer
22. Refrigerant System Cover
23. Door Lift Bracket
24. Levelling Screw
25. Door

Fig. 2.3

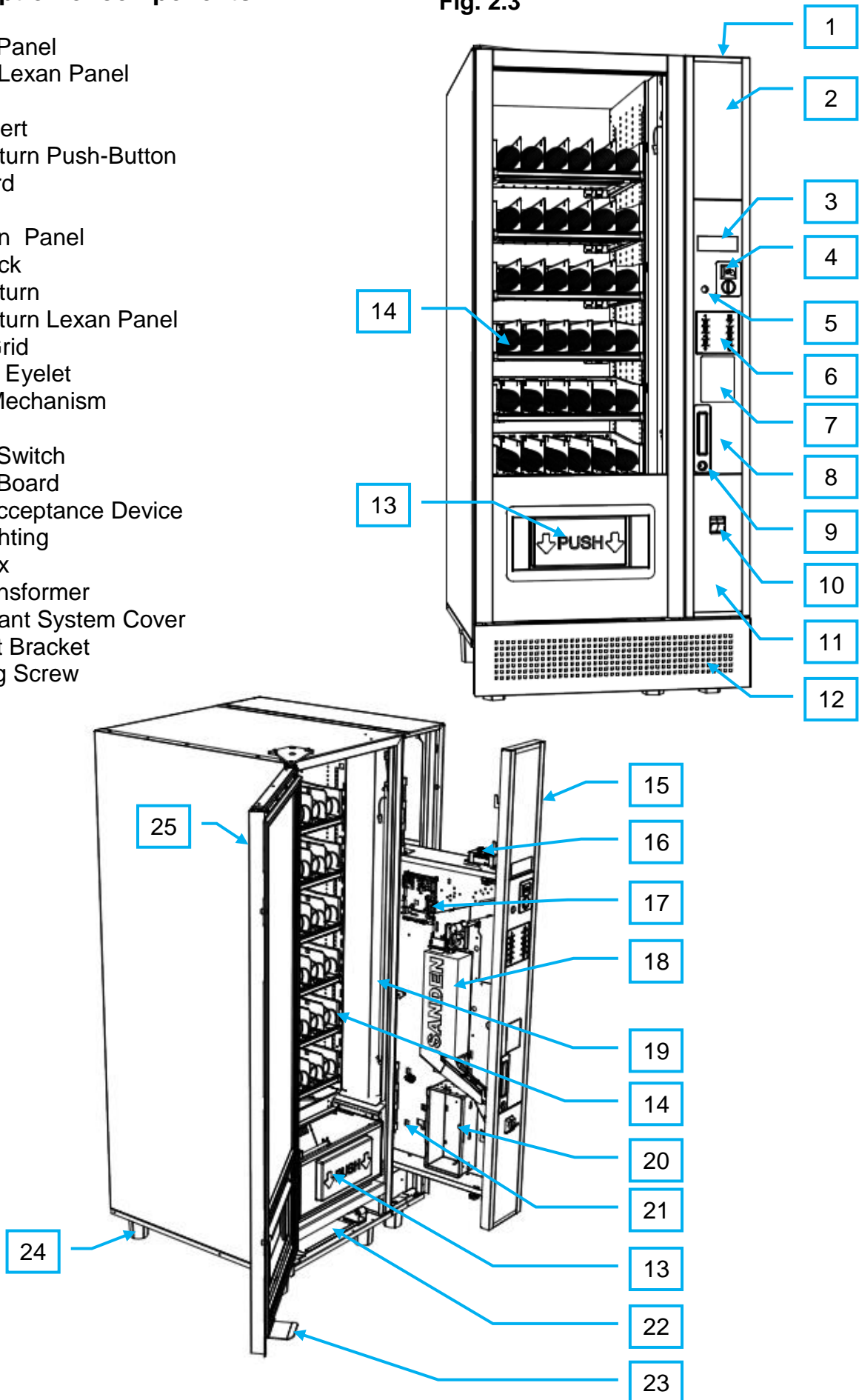

2.5.1 Outdoor External Components

- 1) Heated glass
- 2) Protection trim door glass
- 3) FMP Control Panel
- 4) Out-Door Refrigerant Unit
- 5) Rear cover
- 6) Roof

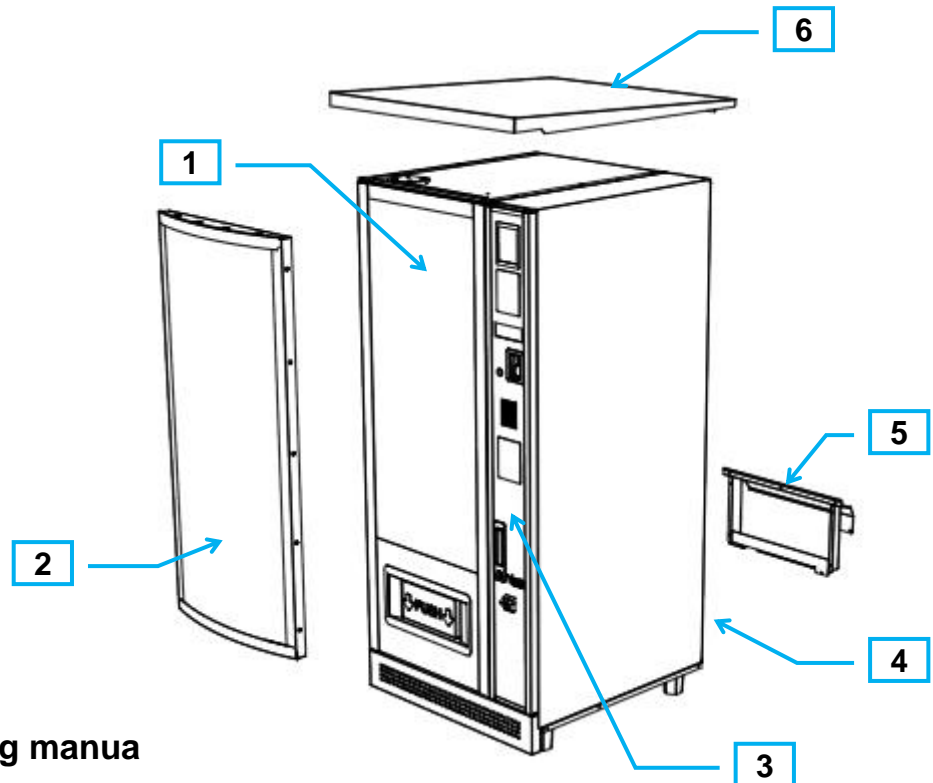

2.6 Referral programming manual

All the machine's control and operation settings can be set through the programming routine of the electronic board.

The programming routine of the electronic board is described in the PROGRAMMING MANUAL supplied with the vending machine.



The referral programming manual will change depending on the version of the software and on the model type:



If the version of the software is 2.xx or more: the programming manual to which you should refer it is p/n 410738.

The software version 2.xx or more it is able to manage the Master - Slave connection.



If the version of the software is earlier than 2: the programming manual to which you should refer it is p/n 412487.

The software earlier than version 2 does not manage the Master - Slave connection.



Models: STX, ST8 and ST6

If the vending machine is equipped with TouchScreen: refer to the programming manual of the new type of software managed through the Linux board.

P/N 415773

3 TRANSPORT, STORAGE AND INSTALLATION

3.1 Transport and Storage

Unloading from the vehicles of transport and handling of the vending machine must be carried out only by competent personnel and with the use of suitable equipment's for the load to be handled.

The vending machine is positioned above two wooden bases, protected by a bag, by four corners and by a retractable film.

Use a forklift, power-driven or manual, to unload the vending machine from the vehicles of transport, the wooden bases allow the sockets on the 4 sides of the vending machine.

Attention!

It is forbidden to transport and / or place the vending machine in a horizontal position;
It is forbidden to drag or lift the vending machine with ropes, slings or other;
Avoid maneuvers that can cause sudden jolts and impacts to the vending machine.



In the event the machine is **mistakenly laid horizontally**, place in the upright position and **wait at least 12 hours** before switching on; otherwise, damage may be caused to the cooling system.



If the vending machine is not used immediately or is stored for long periods, check that it is correctly packaged and positioned vertically.

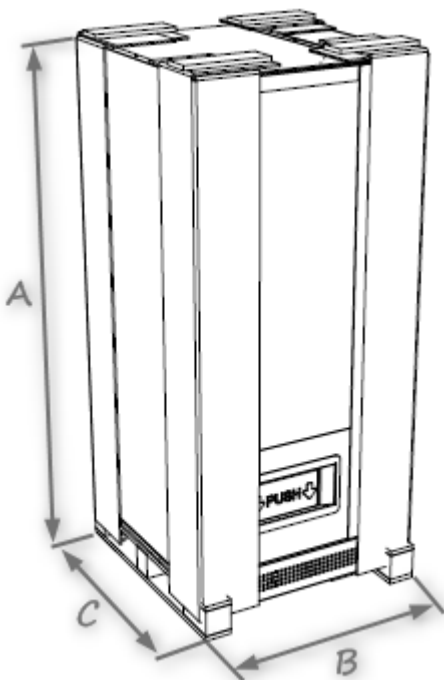

Storage must be carried out in closed but well ventilated places that do not have particular harmful characteristics to the machine components, especially the electronic ones. It is necessary that the environment is dry and with temperatures not lower than 1°C.

Protect the unpainted parts from corrosion with suitable greases or sprays; if necessary, stow it with dehydrating salts.



As long as the vending machine has the original packaging, including wooden bases, it is possible to overlap two.

Attention!

Unpacked vending machines are not stackable.

MODEL	A (mm)	B (mm)	C (mm)	GROSS WEIGHT (Kg)
SDX - SMX - STX	1900	1190	890	340
SD8 - SC8 - SM8 - ST8	1900	1010	890	310
SD6 - SC6 - SM6 - ST6	1900	850	890	275
SDXOD - SMXOD	1960	1300	1100	365
SD8OD - SC8OD - SM8OD	1960	1120	1100	335
SD6OD - SC6OD - SM6OD	1960	1000	1100	300

3.2 Unpacking

Upon receipt of the vending machine check that has not been damaged during transport or that the packaging has not been tampered.



The packaging must be intact, ie:

- It must not present dents, signs of shocks, deformations or breakages of the container;
- It must not have wet areas or signs that could suggest that the casing has been exposed to rain, frost or heat;
- It must not show signs of tampering.



If damaged on receipt, any nature, immediately make a claim to the carrier and notify either the importer or the dealer.



The packaging materials must be carefully removed in order to not damage the distributor, inspect the inside and outside of the container to check for any damage.

- Remove the transparent protective film, the four corners and the bag from the vending machine;
- After removing the external packaging, take the key located in the coin return compartment;
- Open the door, paying attention to the snap movement of the handle;
- Remove the packaging components or equipment supplied which could prevent the correct operation of the vending machine;
- Remove the wooden bases and install the feet as indicated in paragraph 3.2.1
- Install the lower grid as indicated in paragraph 3.2.2.



The packaging materials must be disposed of respecting the environment..



SandenVendo declines all responsibility for damage caused by failure to observe the precautions listed in this section.

3.2.1 Removing the wooden bases

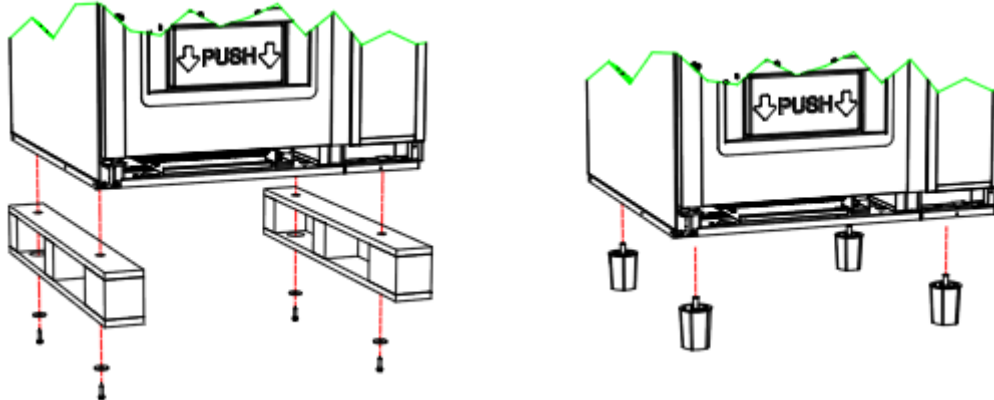

To remove the wooden bases, work as follows:

- Use a forklift, power-driven or manual, to lift the vending machine from the floor with frontal or rear gripping;
- Using a size 10 adjustable spanner (we recommend using a ratchet wrench) remove the screws that fasten the wooden bases to the machine: 2 screws each base;
- Fit 4 feet on to the base of the machine;
- Rest the machine on the floor;

On 6 / 8 selection models with the divisible base, where there are three wooden bases, must be mounted 6 feet.

If don't installed 6 feet you cannot proceed to the division of the cabinet as described in paragraph 3.4.

3.2.2 Installation / Removal Lower Grid

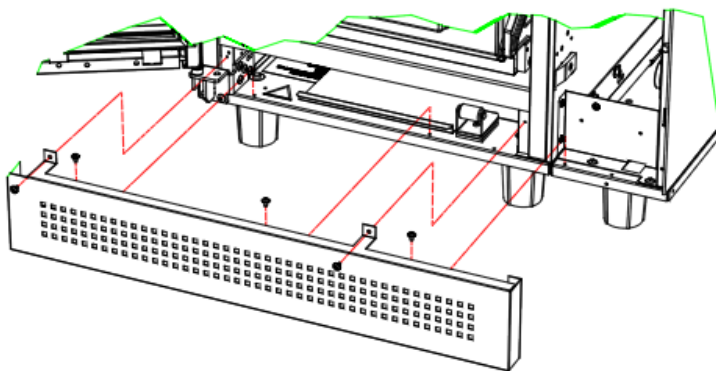

During the first installation, after the positioning of the vending machine, you need to mount the lower grid as indicated on the image.

To be able to move the vending machine with forklift or truck you need to remove the lower grid by removing the screws as shown in the image.
[Do operation only when you must to take the vending machine frontally.]

3.2.3 Supplied Accessories

The following "items" are supplied with the distributor:

- » Use and Maintenance Manual
- » Programming Manual
- » A3 sheet with wiring diagram
- » 4 feet
- » 2 Fuses 10A 250V or 16A 115V
- » 12 screws
- » 2 Micro Activation Keys
- » Sheet A4 Declaration of Gas Conformity
- » Sheet A4 EC Declaration
- » Electrical Compatibility Test Sheet
- » 2 Keys for the lock

3.3 Installation



Before proceeding with **the installation** and use of the vending machine, it is necessary to **read** the contents of **this manual**.



The installation must be carried out by specialized personnel trained to use the appliance according to the manufacturer's instructions and the regulations.

It is necessary to know and respect the safety warnings and danger warnings contained in the manual to work in conditions of minimum risk.

The Vending Machine complies with the latest directives as shown in their Declaration of Conformity, therefore can be installed in both public and industrial environments as long as they comply with the aforementioned points



Attention!

Do not move the vending machine if loaded with products to avoid damage to the appliance.



Attention!

Make sure that the ventilation grilles are always free and not obstructed by dust or similar to ensure perfect ventilation of the refrigeration unit.



Attention!

Do not damage the refrigerant circuit.



SandenVendo declines all responsibility for inconveniences due to non compliance with the positioning rules.

3.3.1 Installation environment features



Attention!

The appliance must be installed in environments / rooms where the temperature does not exceed 32°C and less than 10°C; otherwise the electrical parts (compressor) may be subject to overheating or may not work properly.



Attention!

The appliance is not suitable for installation in outdoor environments and in particularly humid or dusty places without the presence of the "Outdoor Kit".



Attention!

The appliance it is not suitable for installation in environments where water jets are used.



Attention!

Do not place the appliance near heat sources.



Attention!

Do not place the vending machine in direct sunlight.



3.3.2 Placement

Attention!

Make sure that the capacity load of the surface on which the vending machine is positioned is adequate to support the weight declared by the manufacturer;

Attention!

Before connecting vending machine, make sure that the mains power supply has the correct voltage, frequency and power as those indicated on the technical data plate of the vending machine.

Attention!

The appliance must be connected to a power supply network with grounding in compliance with current legislation. The manufacturer can not be held responsible for any damage caused by the lack of grounding system.

- Pull out the service cord from the back of the vending machine through the slot in the rear grill.
- Position the vending machine in the place of installation, operate with caution, avoid maneuvers that can cause sudden jolts and impacts to the machine.
- The appliance must be installed in such a way that the plug is accessible after installation.
- Air circulation is vital for the refrigeration system, check that the distance between the rear of the distributor and any obstacle (e.g. wall) is at least equal to 10 cm (100 mm).
- For optimal operation, we recommend positioning the vending machine on perfectly flat surfaces. Any unevenness in the floor can be compensated by adjusting the screw legs of the distributor in order to obtain perfect leveling and guarantee stability.
- Make sure that the ventilation grilles are always free and not obstructed by dust or similar to guarantee perfect ventilation of the cooling unit..
- If the installation takes place in safety evacuation corridors, make sure that there is still enough space for passage even with door open of the vending machine.
- To ensure smooth operation, always keep the vending machine in perfect clean condition.

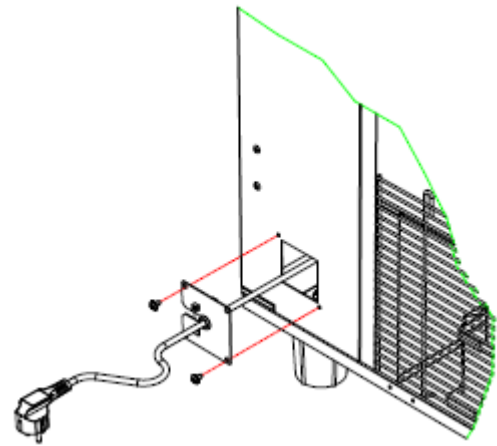

In the event of extraordinary maintenance or repair / replacement of some components, the possibility of rotating the appliance must be provided, in order to be able to access the rear part.

Attention!

SandenVendo Europe declines all responsibility for damages caused to people or things due to:

- Incorrect installation.
- Improper power supply.

3.3.2.1 Installation spaces and spaces of use

Air circulation is vital for the refrigeration system, check that the distance between the rear of the distributor and any obstacle (e.g. wall) is at least equal to 100 mm (100 mm)

If the installation takes place in safety evacuation corridors, make sure that there is still enough space for passage even with door open of the vending machine

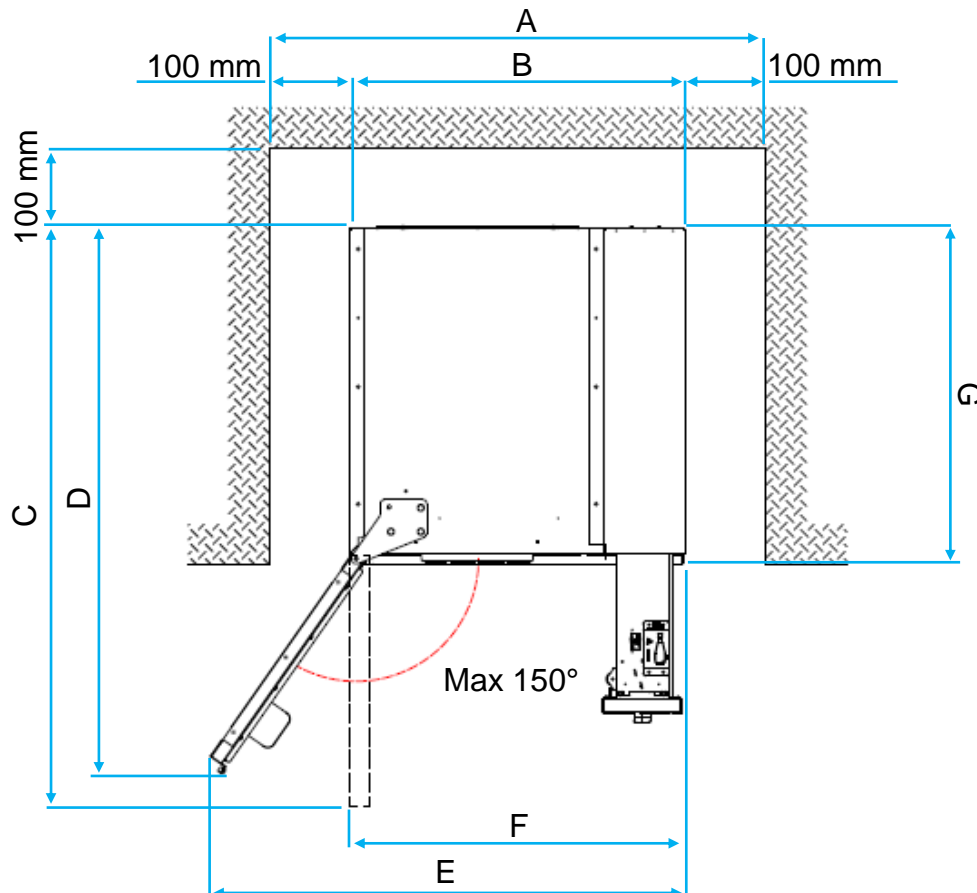

MODEL	A (mm)	B (mm)	C (mm)	D (mm)	E (mm)	F (mm)	G (mm)
SDX - SMX - STX	1325	1125	1735	1310	1890	1125	830
SD8 - SC8 - SM8 - ST8	1180	980	1590	1235	1615	980	830
SD6 - SC6 - SM6 - ST6	1030	830	1440	1160	1350	830	830

External accessories and/or kits of the cabinet could modify the measurements indicated in the table.

3.3.3 Connection to power mains

Service Cord Installation

- Pull out the service cord from the back of the vending machine until the fixing plate comes out.
- Fasten the plate with the two screws.

Before completing the electrical connection make the following checks:

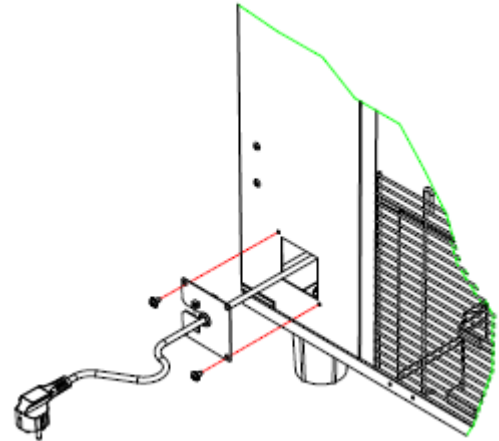

 **Ensure** the mains power supply (voltage and frequency) are the same as those indicated on the machine's rating plate:

Standard Models: this vending machine must be connected to a 230V, 50 / 60 Hz power mains, each voltage below 216.2V or over 243.8V can cause failures.

115V Models: this vending machine must be connected to a 115V, 60Hz power mains, each voltage below 109V or over 221V can cause failures.

 **Ensure** that the main power supply outlet is grounded and that, after making the connection, the entire appliance is ground connected.

 **Ensure** that the appliance is positioned so that the plug connecting it to the mains power supply can be easily accessed after installation.

 **Ensure** that the neutral wire is blue; otherwise, you must invert the poles.

 **Ensure** to use a differentiated protection system.



Attention!

- » The use of adapters, multiple sockets and / or extensions is prohibited.
- » Do not remove the grounding pin from the plug, or in any way do not bypass, modify or destroy the grounding system of the vending machine.
- » Do not bend excessively or place heavy objects on top of the service cord.
- » Do not connect the power with wet hands.



» Should you find any problem with the machine service cord or should it be damaged, it must be replaced. For the safety of personnel and to prevent all risks of damages to the machine never replace the service cord, contact the manufacturer or technical support service.



Attention!

 » For vending machine with the Outdoor Kit, which have a leakage current that can exceed 10mA, it is recommended to install a differential current device (RCD) that has a nominal operating differential current that does not exceed 30mA

3.3.4 Stability

The stability of SandenVendo vending machines against overturning is guaranteed whether the vending machine is empty, full and / or with the door open.

The overturning of the vending machine without external influence is impossible.

However, to protect the machine against vandalism, such as attempts to tilt the vending machine, we recommend to attach one of the following optional kits:

Wall Fixing Kit part number 135078/2

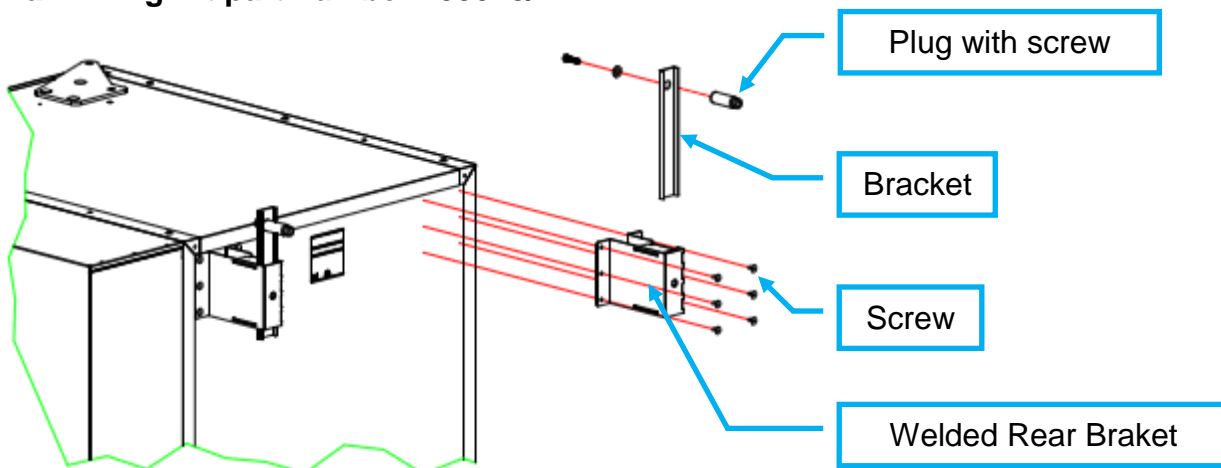

Ground anchor KIT P/N° 139218/1

Use suitable material for secure fixing the vending machine to the floor.

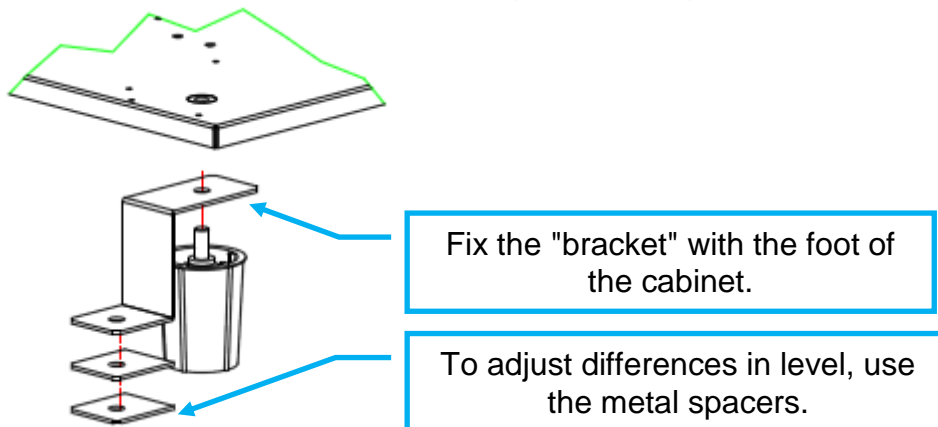

Attention!

SandenVendo does not assume responsibility for any damage caused by the lack of consulting this instructions. All the operations must be done by authorized personnel.

3.3.5 Installing the coin mechanism

⚠ Attention!

Disconnect the power before making any electrical connections, as you may cause damage to the coin mechanism and/or control board.

⚠ Attention!

These operations are not necessary if using the coin mechanism supplied by SandenVendo Europe Spa.

Hook the coin mechanism on the 3 screws (E) positioned on the coin mechanism support (F). Check that the coin slot on the cash box is in line with the outlet of the coin mechanism (G) and that the distance between the two parts is approx. 10 mm max.

Once you have done this, remember to tighten the screws again.

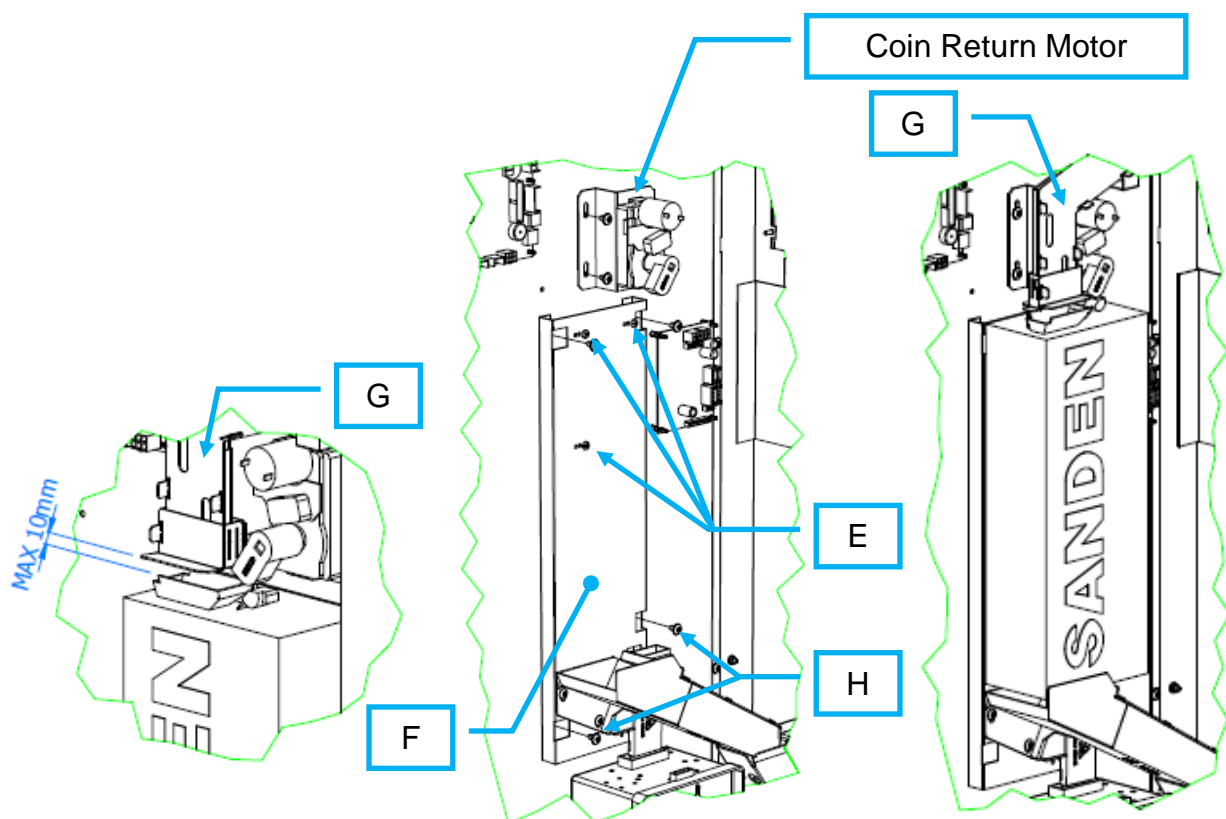

When it is perfectly centered, remove the selector and tighten the 3 support screws (E).

Press the coin return button and check that the mechanism works smoothly. It is important that the selector opens as much as possible. Should this fail to occur, you must again adjust the height of the coin return motor.

3.3.5.1 Coinmech Connection MDB / Executive

MDB

To connect the coinmech in MDB mode, insert the 6-way connector on the SVE01 board or on the EMA0206 board (on TouchScreen models) in position J4.

Executive

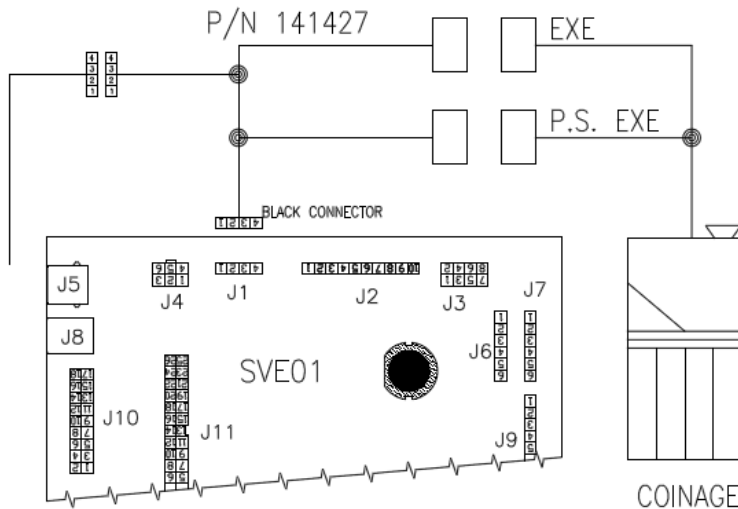

To connect the coinmech in EXECUTIVE mode, it is necessary to use the harness p/n141427 and proceed as follows:

- Insert the black 4-way connector of the harness p/n 141427 in position J1 on the SVE01 or EMA0206 board;
- Insert the 4-way female connector of the harness p/n 141427, on the 4-way male connector previously extracted from the SVE01 or EMA0206 board;

- After connecting the harness p/n 141427, the coinmech can be connected.

3.3.6 Selection labels installation

On the front of the shelf there is a seat suitable for receiving the labels indicating the selectable product code and the price attributed to it.

The labels supplied with the vending machine can be customized by blackening (with the black marker) the unnecessary sectors, until the desired number appears.

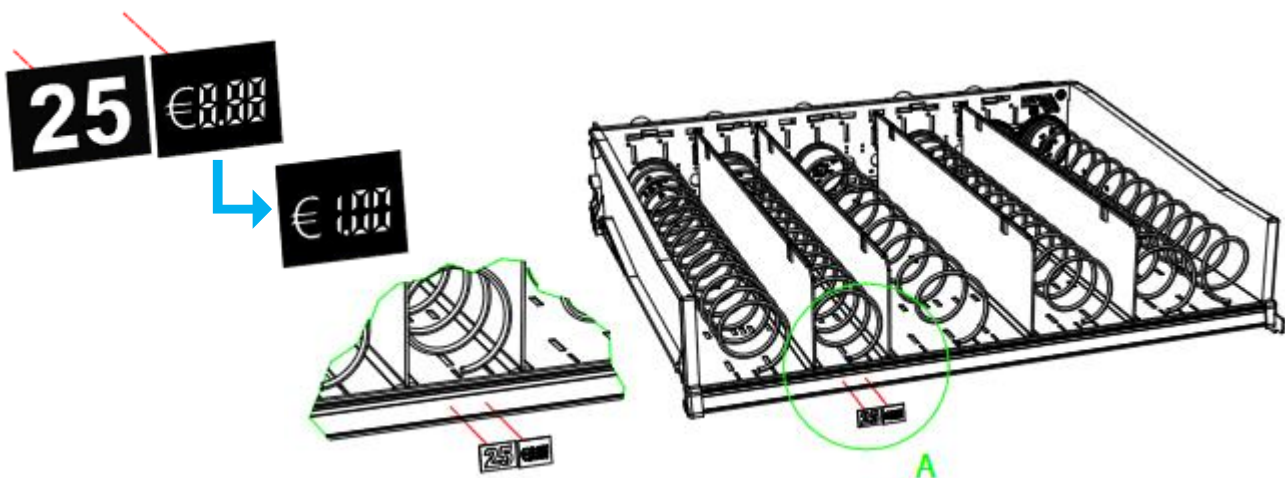

⚠ Attention!

The shelf variant with the price bars do not need the installation of the labels. To set the various messages of the bars, consult the reserved area on the SandenVendo website.

3.4 How to split the model with 6 / 8 selection

- Disconnect the vending machine from the power supply and put the service cord into the drawer;
- Make sure the vending machine is stood on 6 levelling feet;
- Open the drawer and remove the fixing bracket (image 1)
- Disconnect all the harnesses that coming from the cabinet (N.B. the ground wires are fixed with screws) then remove the drawer form the vending machine;

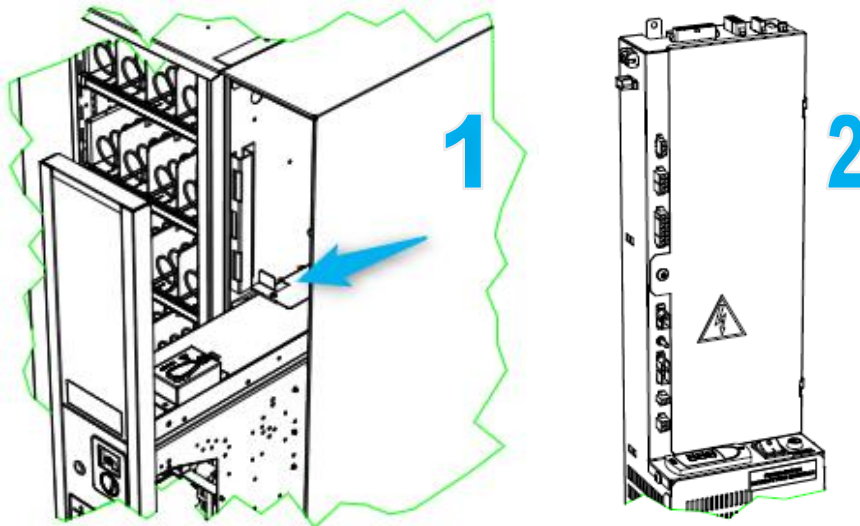

- Remove the carter under the door (image 3)
- Remove the first screw that fixes the base bracket blocker and loosen the other two (image 3)
- Slide upwards the base bracket blocker along the slot

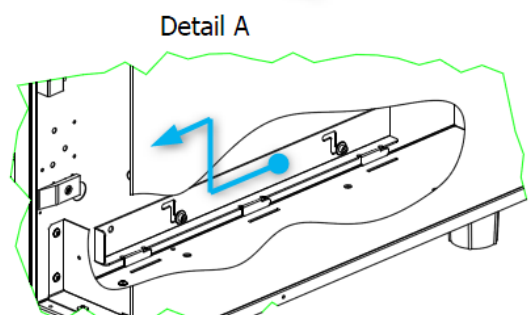
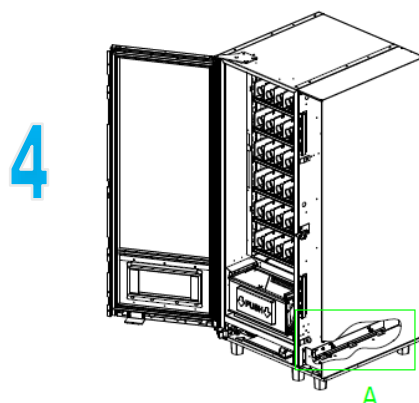
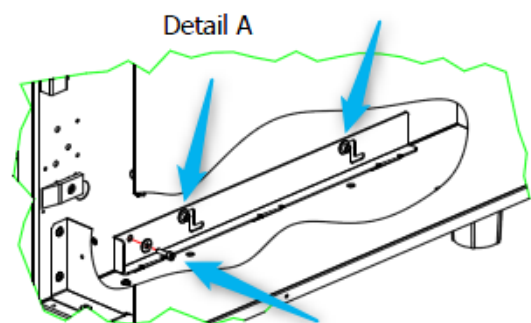
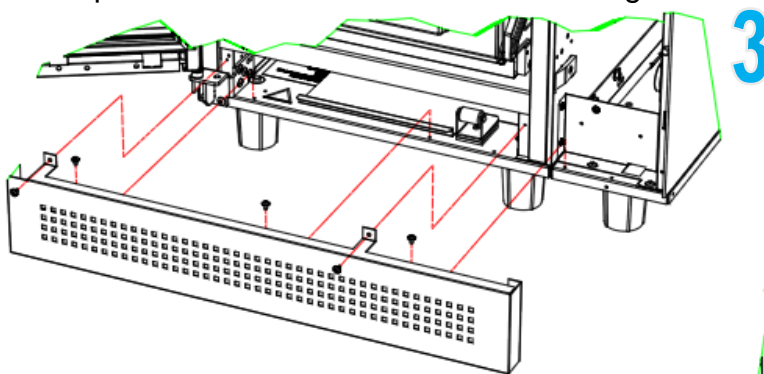

- Remove the screws at the bottom on the cabinet (image 5)
- Unscrew the two screws that fix the control panel box

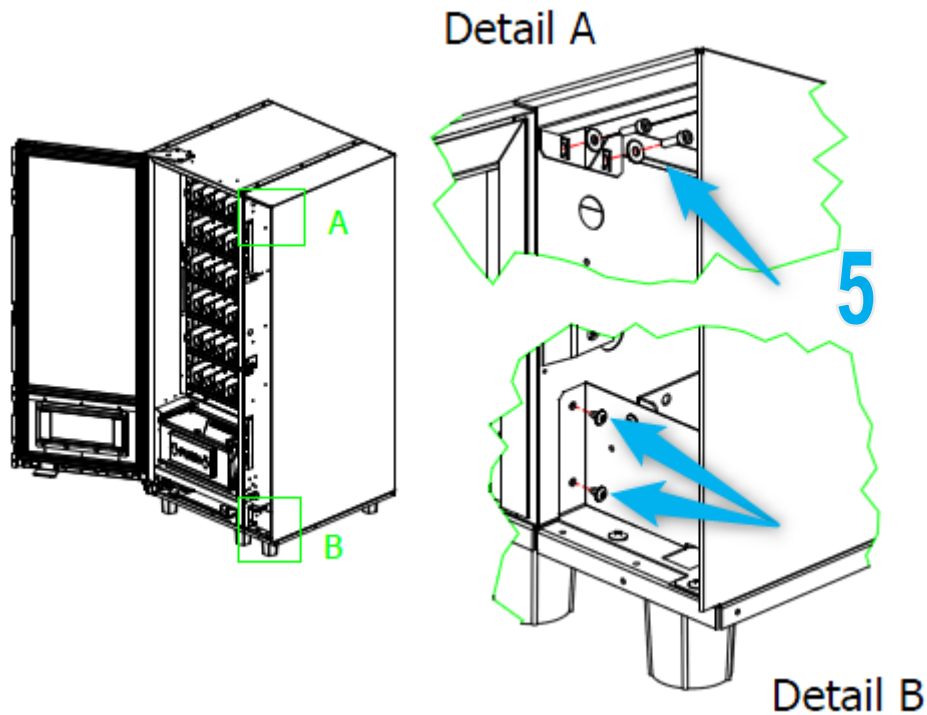

- Push the control panel unit backwards forcefully to release it from the screws on the back of the cabinet (attention: The control panel unit now is separated from the cabinet)

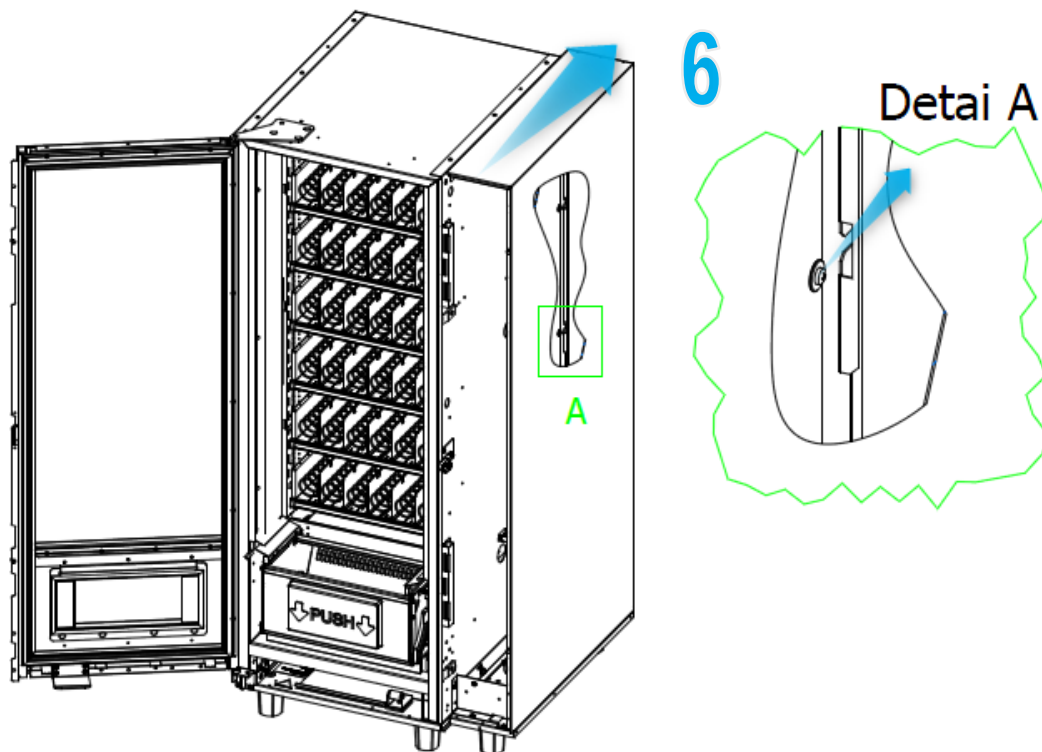

- » To assemble the machine it is necessary to follow the instructions in reverse:
The connectors coming from the machine are unique and can only be connected in the predisposed positions.

4 Use and Operation of the Vending Machine

4.1 Proper Use

The "**G-Snack Design Line**" vending machine have been designed and manufactured exclusively for the sale and automatic distribution of packaged products. The vending machine must be used exclusively for the distribution of products in hermetically sealed packages.



The appliance goes into normal operation if the mains power supply is connected and the door and drawer are closed.

Using the keyboard, it is possible to select the product viewed through the window on the front door.

On the lower part of each shelf there is a label indicating the selectable product code and the corresponding price.

The button necessary for selection are numbered from 1 to 9 and by typing the desired combination (31, 55, etc.) the choice of the product to be dispensed is determined.

When the products run out, the associated selection is disabled, and in the event of a request for the same selection, a message appears on the display informing the user of the availability status (until the list of errors is deleted).

In normal operation, the vending machine goes into standby status.

After inserting the credit, in coin / carat, key or other, you can press the key combination of the desired product.

If the credit is sufficient and the product is available, the dispensing cycle is activated.

If installed and enabled, the elevator tray moves to the height of the shelf from which the product was selected.

The motor of the column in which the selected product is located performs a rotation making the product fall into the withdrawal compartment directly or accompanied by the elevator.



To view the price of a selection on the display, you can press the desired combination (31, 55, etc.), before inserting the credit.

The vending machine is not a refrigerator, but allows you to moderately refrigerate the products that are loaded.

Any other use is to be considered improper use and therefore at risk.

Do not introduce potentially dangerous products into the vending machine due to inadequate temperatures. In this regard, follow the instructions on the products for the conservation rules and the expiration dates of the same.

4.1.2 Distribution capacity

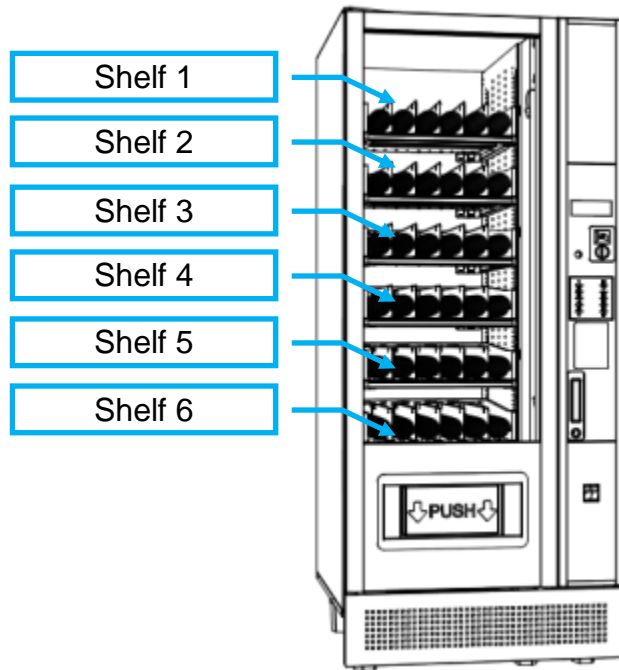

Model	Selves quantity	Spiral quantity each Shelf
SDX - SMX - STX	Minimum 4 Maximum 7	Maximum 10
SD8 - SC8 - SM8 - ST8		Maximum 8
SD6 - SC6 - SM6 - ST6		Maximum 6

The spiral size are:

	Diameter Ø	Length	Step	Product quantity
Spiral LH / RH	64.5 mm	472 mm	11 mm	42
			18.5 mm	24
			25 mm	17
			30 mm	14
			35 mm	12
			45 mm	10
			55 mm	8
			65 mm	7
			85 mm	5
			40 mm	11
			77 mm	6
			95 mm	4
			105 mm	4
	120 mm	472 mm	120 mm	4

SandenVendo reserves the right to approve the vend of all products which are not perfectly cylindrical only after testing them.

SandenVendo is not responsible for uses and applications of the vending machine that are not covered in the explanations in this manual.

4.2 Access to internal parts

Attention!

The opening and activation of the vending machine with the door open must be entrusted exclusively to personnel authorized to perform these operations.
Do not leave the vending machine open unattended.

Access to the internal part of the machine (**Maintenance / Loading Zone**) is only possible through the appropriate key of the lock supplied with the vending machine.

Two silver colored keys are supplied with the vending machine to be used for the normal use of opening and closing, placed inside the coin return compartment.

 On request, a golden key is also provided which functions as a programming key as it is able to internally reset the lock itself.

Attention!

The golden key must not be used for daily use!
In fact, a regular and prolonged use of this key can damage the lock internally making it unusable.

4.2.1 Safety devices

The vending machine is equipped with a safety switch that disconnects the voltage from the vending machine's electrical system whenever the drawer is opened.

For some operations, however, it is necessary to operate with the door open and the vending machine active.

To energize the system with the door open, simply insert the appropriate blue plastic key supplied with the vending machine, into the switch on the top of the drawer and turn them 90 °.

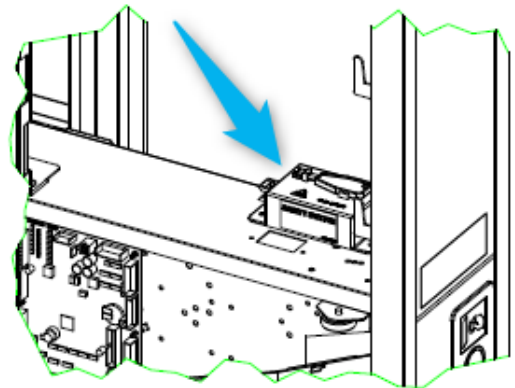

 Each time the vending machine is switched on, a diagnostic cycle occurs to check the position of the moving parts.

Attention!

The door can only be closed after removing the blue plastic key from the switch.

Attention!

Complete isolation from the mains is obtained only by disconnecting the plug.
Therefore all the operations that require the vending machine with the door open must only be carried out by qualified personnel who are aware of the specific risks that this condition entails.

4.2.2 Board

4.2.2.1 SVE01 Board [only with SVE01 control board]

J1. In/Out Coinage System Executive

J2. DEX / UCS

J3. Communication I2C

J4. In/Out Coinage System MDB

J5. Communication USB

J6. Communication RS485

J7. Communication <--> RS485 to SVE02 / SVE03 / SVE05

J8. Communication USB

J9. Analog (ambient probe / evaporator probe)

J10. Display

J11. I2S/GP In / Out

J12. Door Switch

J13. JTAG

J14. Input microswitch

J15. Keyboard (matrix)

J16. Output motor 24 vdc

J17. LED

J18. Board SVE01 Alimentation

J19. General purpose input

J20. Coin return motor

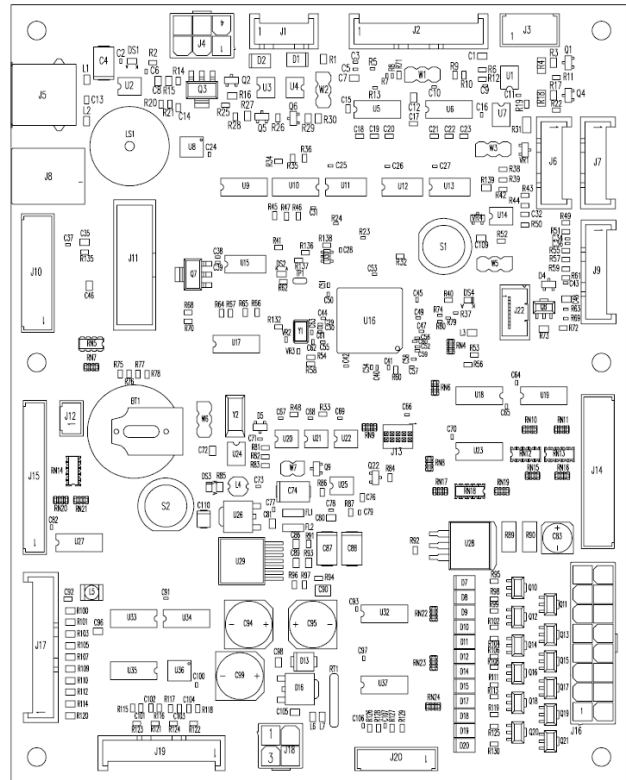

4.2.2.2 SVE02 Board [only with SVE01 control board]

JG1. Optical Barrier

JG2. Micro Switch

JG3. Shelves

JG4. Motors Shelf

JG5. Communication RS485 to SVE01

JG6. Communication RS485 to SVE01

SP2. Jumpers (Slave-address / Reserved / Bootloader)

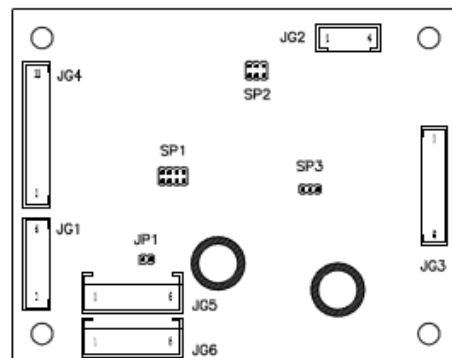

4.2.2.3 Relay Board [only with SVE01 control board]

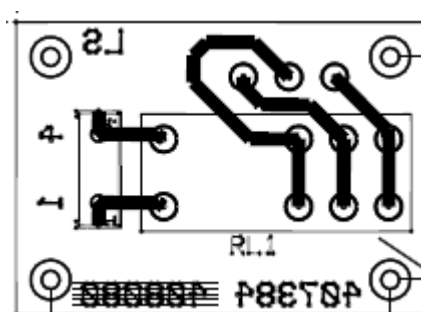

4.2.2.4 Elevator Motor Board (Optional)

This board is present only on models that have installed the elevator.

J1. CAN BUS (to EMA0226)

J2. CAN BUS (to EMA0226)

J3. RS-485 (to SVE01)

J4. Microswitches (Lift)

J5. MOTOR (Power and encoder)

J6. Board Supply

J7. Reserved for technicians

J8. Reserved for technicians

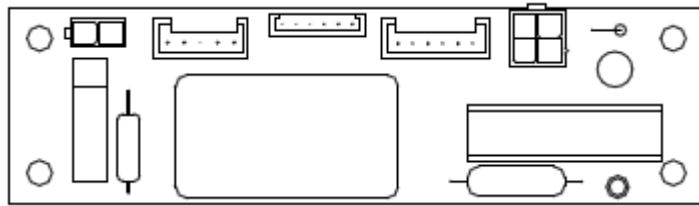

4.2.2.5 SVBA E-Labeling Board (Optional)

This board is present only on models that have the shelf with price bars installed.

CN1. Communication I2C to SVE01

CN2. Communication RS-485 to price bars

SW1. Microswitch for setup: MASTER/SLAVE

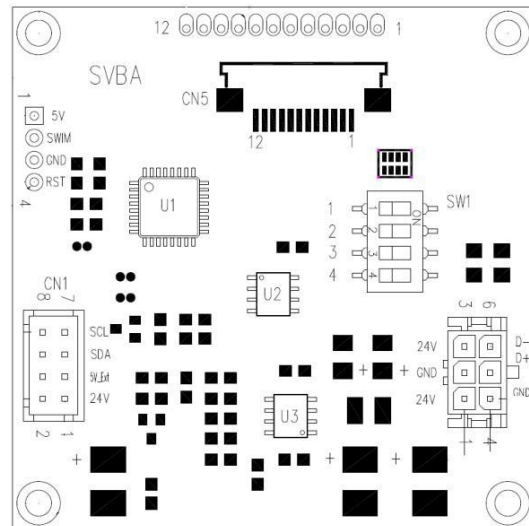

4.2.2.6 Control board EMA0206 [only with Linux control board]

J1. Keyboard Input

J2. Dex - Ucs

J3. MDB

J4. Executive

J7. Power supply 24 VDC

J9. Can - Bus

J11. Ethernet

J13. USB

J14. Serial TTL

J15. Display

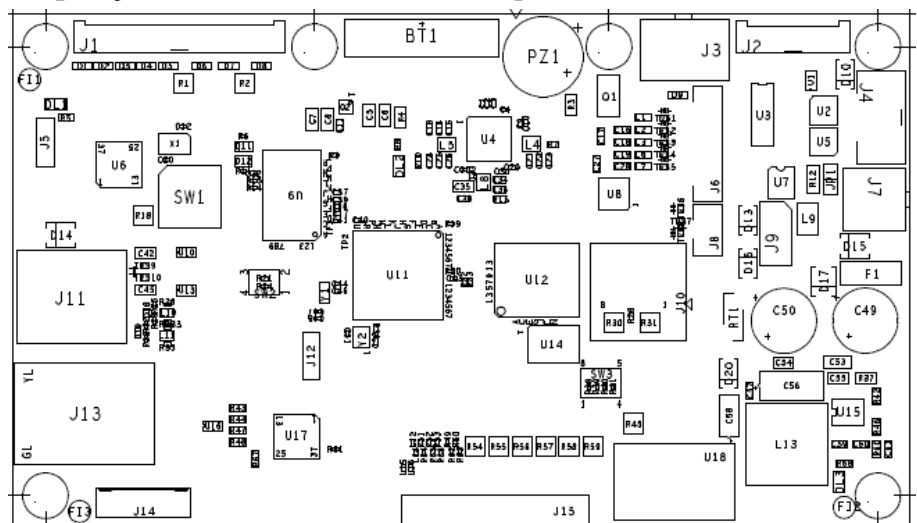

4.2.2.7 Interface board EMA0212 [only with Linux control board]

- J6. Connection with control board
- P1. Button to enter the programming menu

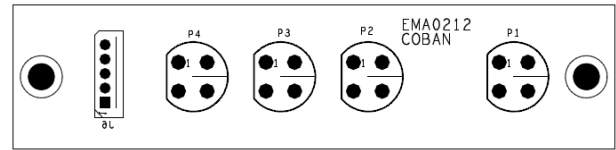

4.2.2.8 Board EMA0240 (Optional) [only with Linux control board]

- J1. CANBUS
- J2. CANBUS
- J4. Input
- J5. Mtr Lift/Encoder
- J6. Power Supply

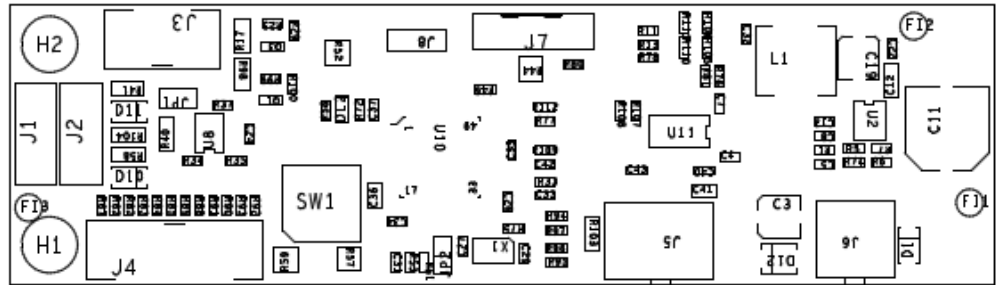

4.2.2.9 Board EMA0226 [only with Linux control board]

- J1. Ambient probe
- J2. EMA0212 Board Connection
- J3. Front door
- J4. Machine detection
- J5. Optical barriers
- J6. Serial I2C
- J7. MDB
- J8. Programming
- J9 – J10. CAN to Linux

- J11. Coin return motor
- J12. Debug Serial
- J13 – J14. Connector CANB
- J15. Power Supply 24VDC
- J16. Connector RS485
- J17. Door product
- J18. Machine lighting
- J19. Line sales connector
- J20. Column sales connector

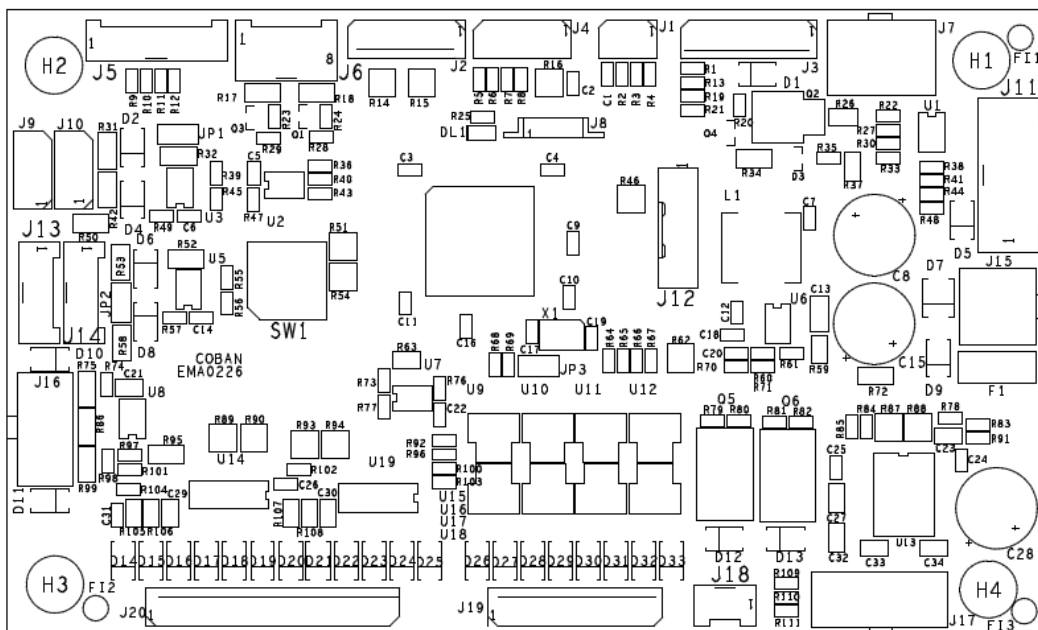

4.2.3 Products Charging

⚠ Attention!

Never load the vending machine with products different to those recommended by the manufacturer.

⚠ Attention!

Never load the vending machine with product formats different from those recommended by the manufacturer.

⚠ Attention!

Follow the manufacturer's instructions regarding the expiry dates of the products and the maintenance temperature.

⚠ Attention!

To avoid problems, the operator in charge of filling the vending machine must not activate the safety switch.

For loading operations, follow the instructions below:

- Open the vending machine door;
- Remove one shelf at a time, slightly lift the shelf and pull outwards until it reaches the locking point. The tray would tilt downwards facilitating the loading;

Note: It is possible to change the guides to make the shelf tilt more when fully extracted.

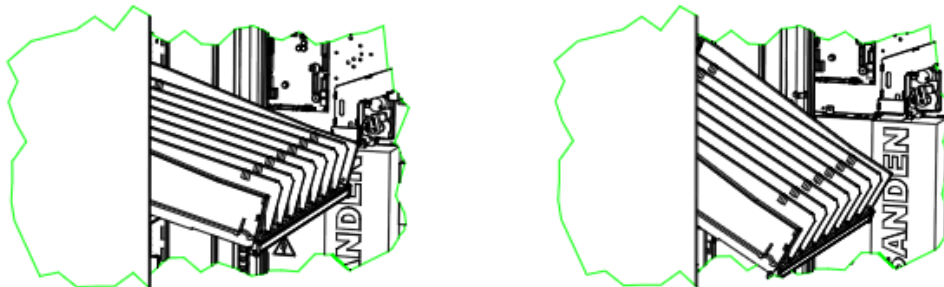

- Proceed with the loading of the products starting from the inner parts (motor side) until reaching and completing the spaces of each spiral.

⚠ Attention!

When not all the spiral slots are filled, it is recommended to load the products starting from the front of the tray inwards.

⚠ Attention!

The bottom of the product (snack and/or drink) must rest on the bottom of the compartment with the label facing the window so that it is recognizable.

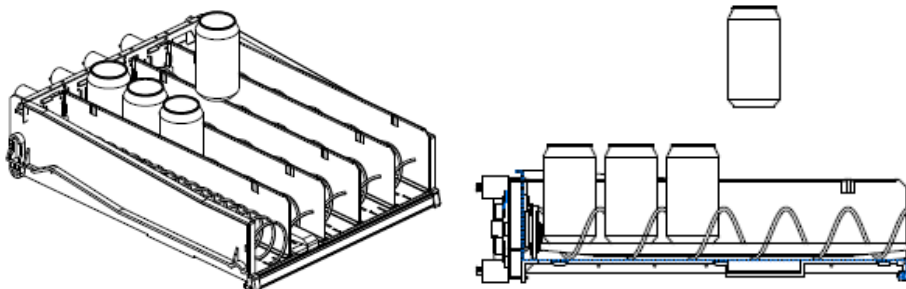

⚠ Attention!

Use the appropriate accessories for the loaded product.

⚠ Attention!

When filling the spirals, check that the products are not too tight in their housing. Do not force the insertion of the products into the slot of the spirals because the product must slide out thanks to its weight. If necessary, replace the spiral with one with a larger step;

⚠ Attention!

Avoid placing products whose edges can get in the way during sliding.

⚠ Attention!

Avoid introducing packages at temperatures above 30°C.

⚠ Attention!

Particularly thin products can only be distributed with the use of the special spacer.

⚠ Attention!

The sealed edge of the bags can slip under the spiral, preventing the bag from falling. Fold it forward and up before inserting it into the spiral.

⚠ Attention!

If the temperature divider kit is present, load the cans and bottles underneath the position of the kit.

- Put the shelf back inside of the vending machine and make sure that the connection has taken place;
- Close the vending machine door and wait for the parameter configuration reset check..



Common products are normally tested at the factory. Ask for the setting number of the product you want to sell and refer to this number when ordering. We will make the vending machine according to your specifications.

4.2.3.1 Configuration of the vending machine for 2 temperatures

The vending machine can be configured for 2 different temperatures inside the refrigerated cell, one for the sale of the food products (lower area) and one for the snack products (upper area).

⚠ Attention!

The maintenance and the sale of the fresh perishable products should be done in accordance with the law regulations in force, which obliges to respect the cold chain throughout the transportation, till the product is supplied to the final client. Therefore, all the products loaded inside the vending machine in “food” area should already have suitable preservation temperature. Also in case of selling the non-perishable product in the “food” area (such as bottles and cans) along with the perishable products, all products should have the preservation temperature. This is to avoid the vending machine to go out of order, caused by an increase of mass temperature, as a consequence of loading the warmer products which increase the temperature of other products.

Illustrative table of the vending machine internal temperature with sub-division of 2 areas; 3 “Food” and 3 “snack” cassettes

Set temperature 1°C				
Ambient temperature	3 Food shelf temperature	4 th Snack shelf temperature	5 th Snack shelf temperature	6 th Snack shelf temperature
20°C	0÷4°C	3.3°C	3.6°C	4.7°C
25°C	0÷4°C	4°C	4.3°C	5.7°C
32°C	0÷4°C	5.3°C	5.8°C	8°C

Recommendation for correct product loading

When the Vending machine is set with 2 different temperatures; “food” and “snack”, especially in the hot period (high ambient temperature), we recommend to proceed the product loading in the following order; “snack” products first and then all the “food” products.

Doing this way, the perishable products, which are more sensitive to heat, will remain intact till the last instant in the refrigerated container which is used for the transportation. The products will be loaded into the vending machine at the optimal temperature, without being affected by the sudden change in temperature.

Loading operation should always be done as quickly as possible, in order not to alter the quality and freshness of the products and roughly in the time range of 10 minutes.

4.2.4 Shelf Adjustments

Depending on the size of the products to be distributed, each vending machine can be equipped with a variable number of shelf (maximum 7) with spirals of different pitch and various kits for particular products.

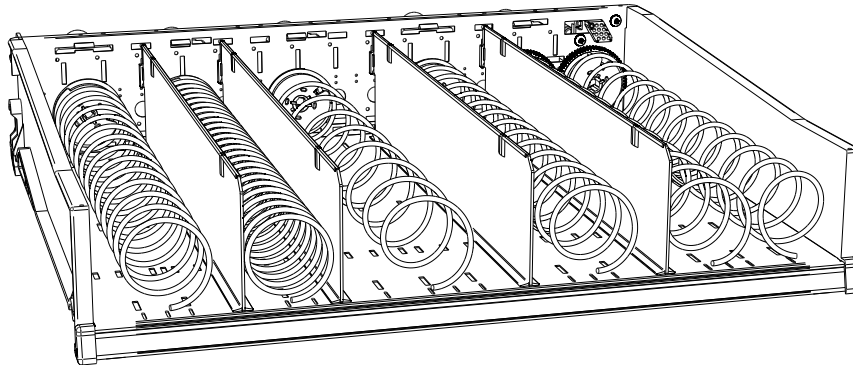

Example of some accessories available:

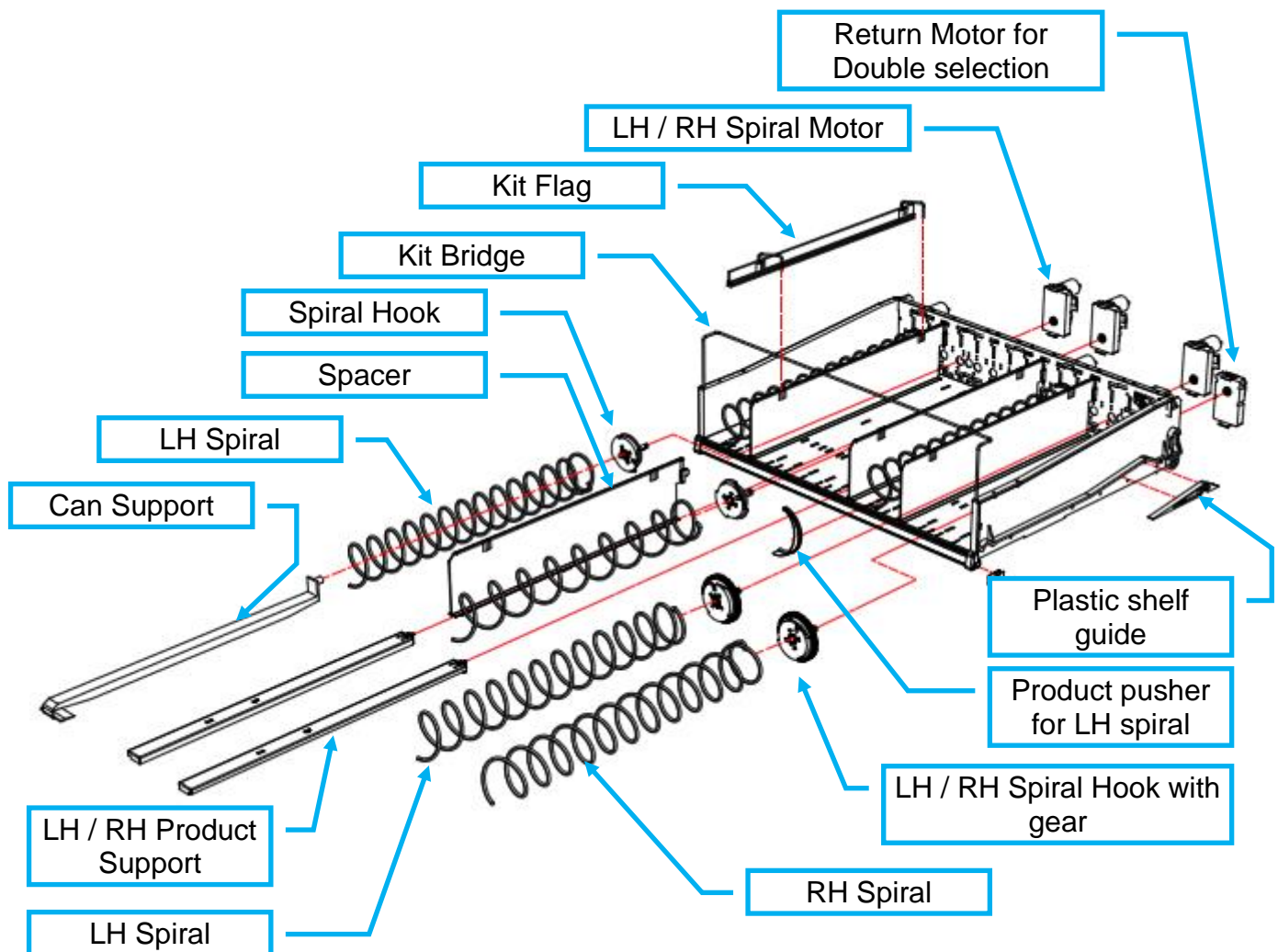

Using an advanced configurator, created by SandenVendo, it is possible to create the layout of the machine in the way that best suits the customer.

Shelf Examples with the various Selection Types available.

Single Selection

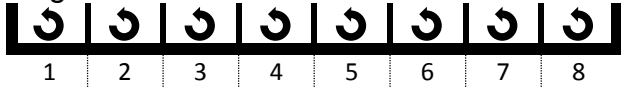

One and a Half Selection (1.5)

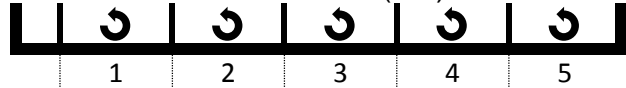

Double Selection with 1 LH Spiral

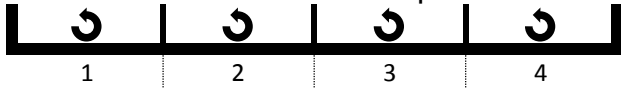

Double Selection with 2 Spirals LH-RH

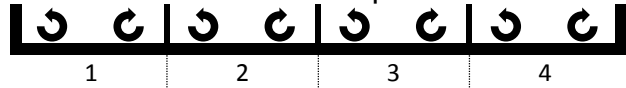

Double and Half Selection with 1 LH Spiral (2.5)

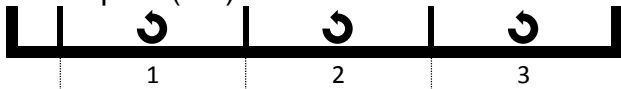

Double and Half Selection with 2 Spirals LH-RH (2.5) [Kit Sinchro]

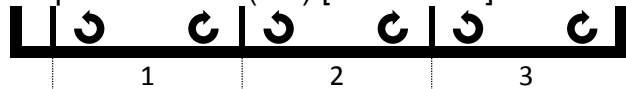

Triple Selection with 1 LH Spiral



Triple Selection with 2 Spirals LH-RH [Kit Sinchro]



Enlarged Selection [Kit Sinchro]



4.2.4.1 Shelf "Spiral Ø120" (Optional)

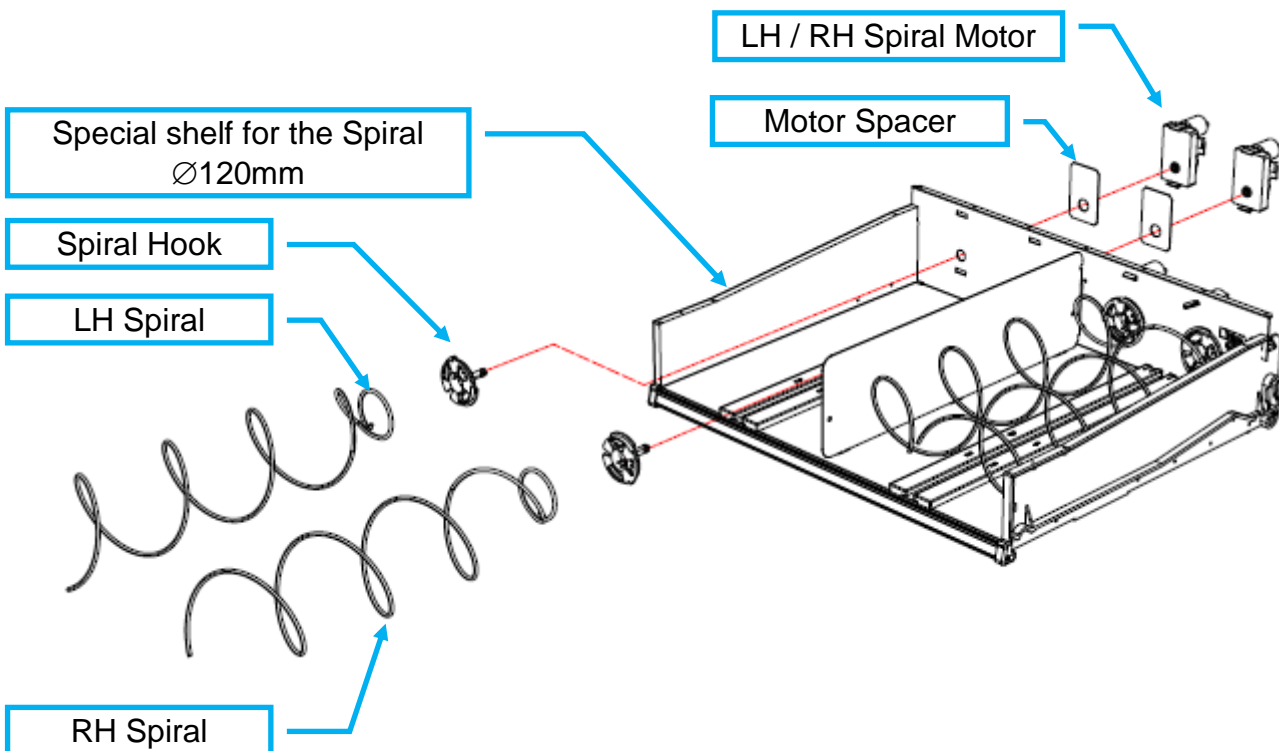

4.2.4.2 Shelf with E-Label (optional)

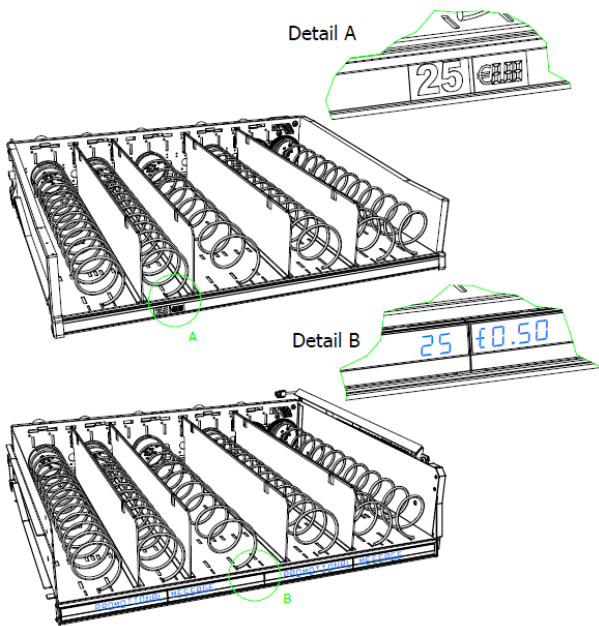

Among options of the models **G-Snack Design Line** is also available a new version of the shelf with the electronic label (E-Label).

The shelf with E-Label is connected with the software of the vending machine, it is possible to activate the viewing of an advertising or only the price of the selections. [check the programming manual for further details]

When is activated a configuration of the selection the vending machine set automatically the dedicated area of the display for each selection and it is viewing only the numbers of the detected selections.

On the SandenVendo website, in the area reserved for customers, it is possible to customize the names of the products and the prices to be shown on the display of the shelf. Follow the instructions on the site to change the parameters of the price bars.

4.2.4.2.1 Dip-Switch Settings of the Price Bars and Boards

On the price bar and on the board there are dip-switch that have to be set in the following way, otherwise the e-label function don't work correctly. The default price bars and boards dip-switch are set as indicated in the following table.

» Price Bars (E-Label) Settings

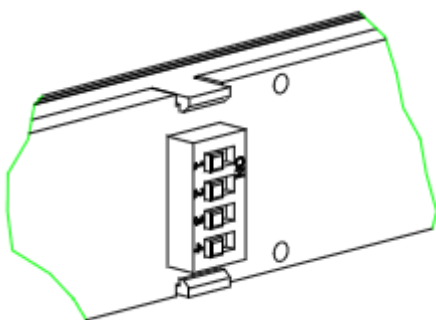

Switch Position				SHELF
BIT 1	BIT 2	BIT 3	BIT 4	The number <u>1</u> is the first shelf from bottom
ON	ON	ON	4	1
1	ON	ON	4	2
ON	2	ON	4	3
1	2	ON	4	4
ON	ON	3	4	5
1	ON	3	4	6
ON	2	3	4	7

» Boards Setting



Switch Position				VENDING MACHINE TYPE
BIT 1	BIT 2	BIT 3	BIT 4	
ON	2	3	4	MASTER
1	2	3	4	SLAVE

4.2.4.3 “Belt” Vending System

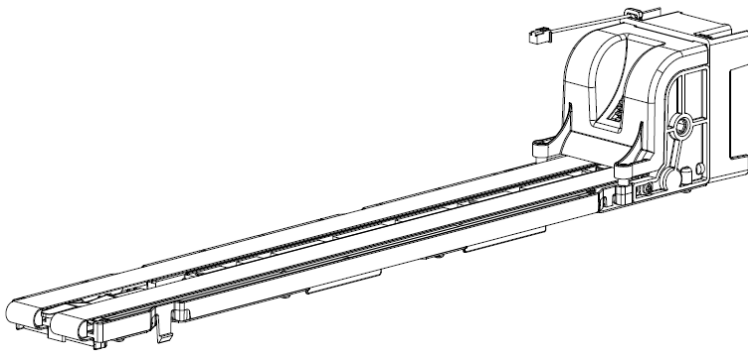

⚠ Attention!

Do not load products that are deformed or that have ears or various protrusions. This may cause problems when selling the product.

⚠ Attention!

Using the system, load the column with the relevant products for which the various parameters are set up on software.

⚠ Attention!

We recommend only loading products with a flat bottom. Test that the products are delivered efficiently, before putting them on sale.

⚠ Attention!

When loading the product, position it centrally in relation to the selling mechanism. Loading the products randomly could block the products from sliding properly.

⚠ Attention!

When loading the products, make sure they do not scrape against the sides of the column, otherwise problems may occur during the product delivery.

» Check the programming manual to know how to program the vending machine for sale.

4.2.4.3.1 Delivery type “Limit Switch”

» When this mode is set, the belt continues to move the products until the limit switch has changed status twice (it activates and then deactivates, or deactivates and then reactivates).

When loading for vending:

» Load the products as far forward as possible (to avoid waiting times that are too long during sales, or failed deliveries)

In this case, whether the limit switch is activated or not does not matter when the column is loaded.

We recommend leaving a gap of a few millimetres from the front of the vending mechanism, to avoid unwillingly dropping of the products.

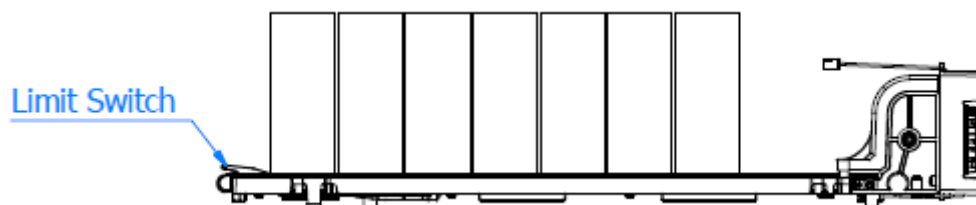

4.2.4.3.2 Delivery type “Step”

» When this mode is set, the products loaded are delivered based on a step that must be calibrated using the relevant menu (Delivery step calibration).

When the product is being delivered, pressure on the limit switch is not taken into consideration.

» When this product delivery system is activated, the step for the products must be calibrated.

When loading for vending:

» Load the products as far forward as possible (to avoid waiting times that are too long during sales, or failed deliveries)

In this case, whether the limit switch is activated or not does not matter. when the column is loaded

We recommend leaving a gap of a few millimetres from the front of the vending mechanism, to avoid unwillingly dropping of the products.

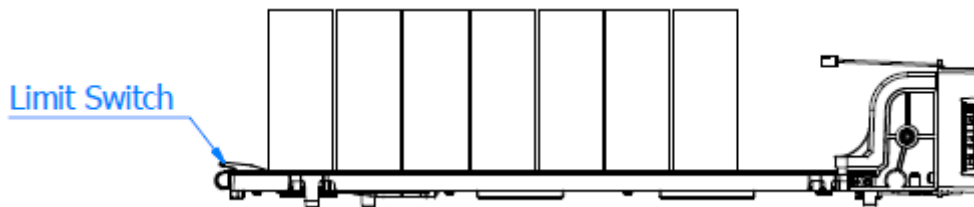

4.2.4.3.3 Delivery type “Step and Limit Switch”

» When this mode is set, the products loaded are delivered based on a step that must be calibrated using the relevant menu (Delivery step calibration).

When the product is being delivered, the first change of status on the limit switch, will adapt the step again for an optimum sale. Changes after the first in status of the micro switch, during the delivery time, calculated via the calibration, are not taken into account.

» When this product delivery system is activated, the step for the products must be calibrated.

When loading for vending:

» Load the products as far forward as possible (to avoid waiting times that are too long during sales, or failed deliveries)

In this case, the limit switch must not be activated, do NOT position products on top of the limit micro switch.

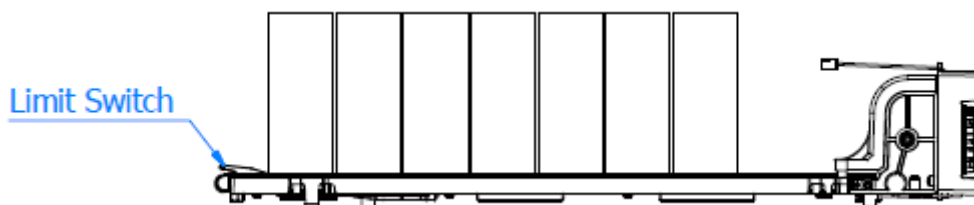

4.2.4.3.4 Delivery type “Programed Step”

» When this mode is set, the products loaded are delivered based on a step that must be calibrated using the relevant menu (Delivery step calibration).

When the product is being delivered, pressure on the limit switch is not taken into consideration.

» When this type of product delivery system is activated, the step to be used in relation of the graphic indications marked on the side of the conveyor belt, must be set.

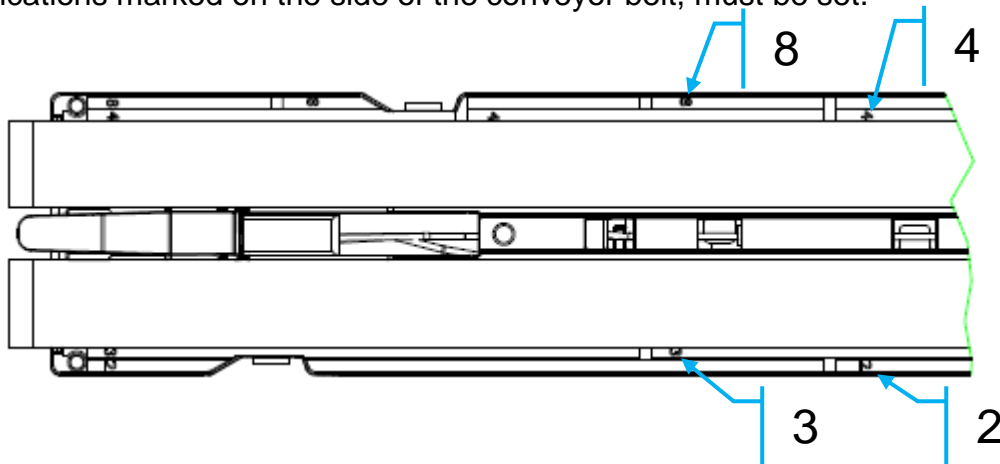

When loading for vending:

» Load the products, centring them within the step indicated in the graphics on the side of the conveyor belt. (to avoid waiting times that are too long during sales, or failed deliveries)
In this case, whether the limit switch is activated or not does not matter when the column is loaded.

We recommend leaving a gap of a few millimetres from the front of the vending mechanism, to avoid unwillingly dropping of the products.

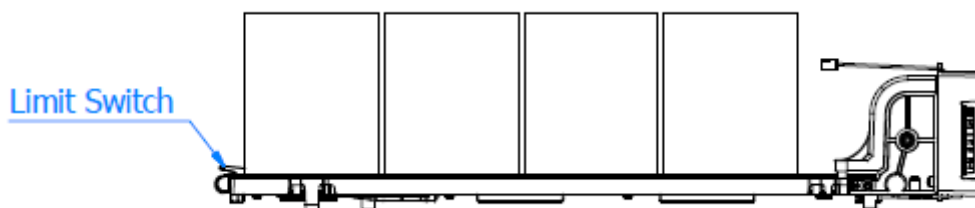

4.2.4.4 “Rotary” Vending System

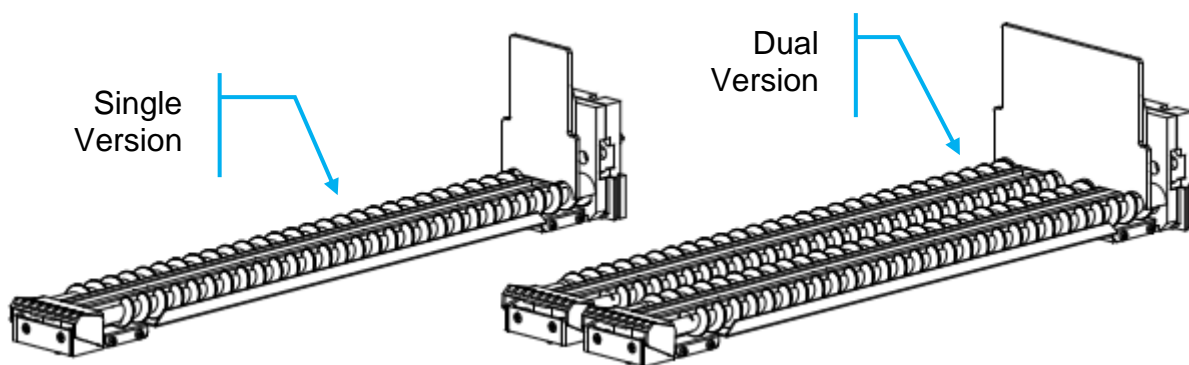

» To divide selections when using the “Rotary” system, use the special dividers shown in the figure.
 The STD plastic dividers cannot be installed, when using these vending mechanisms..

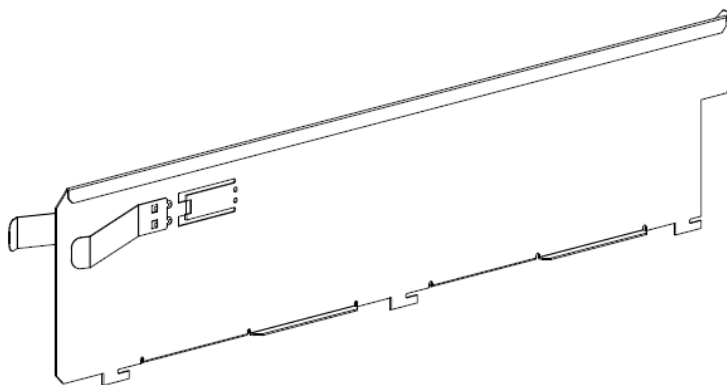

» Single Version Installation

Each single rotary system must be connected to a STD motor

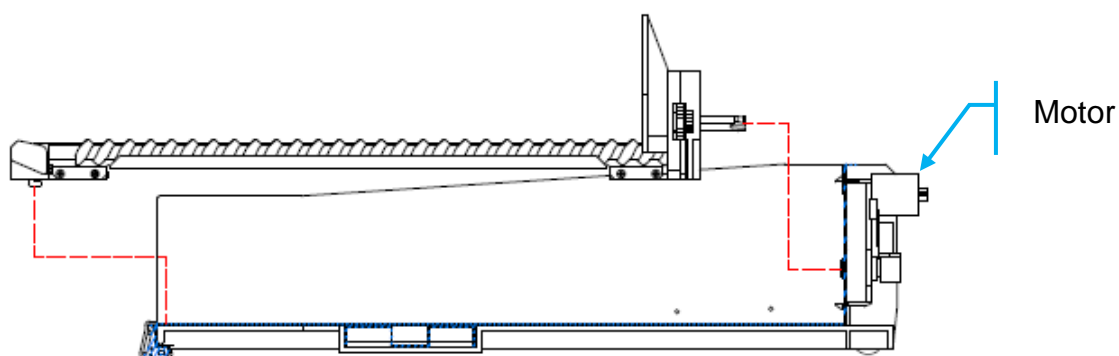
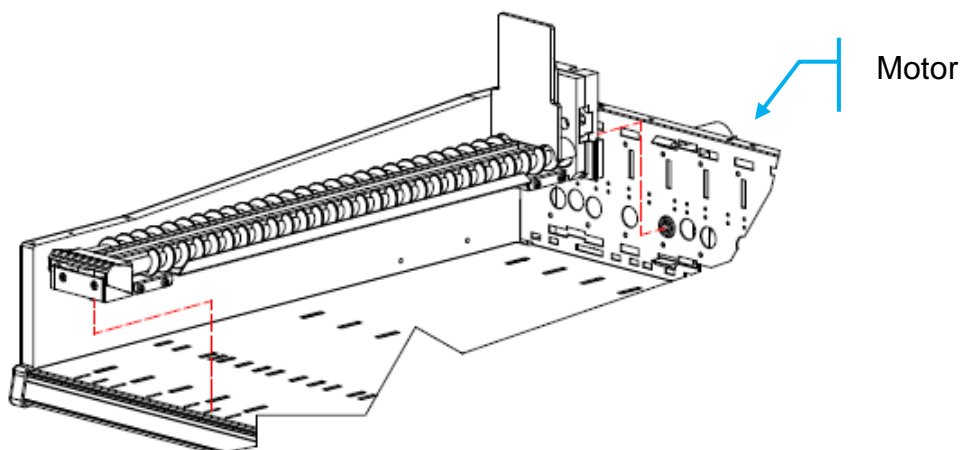

Depending on the position at which the single “Rotary System” is installed, the two vending mechanisms must be joined or installed side-by-side.

Vending mechanisms joined as indicated below

Side-by-side vending mechanisms

The two mechanisms must be joined when 2 rotary systems are installed in the positions indicated for the “dual version”

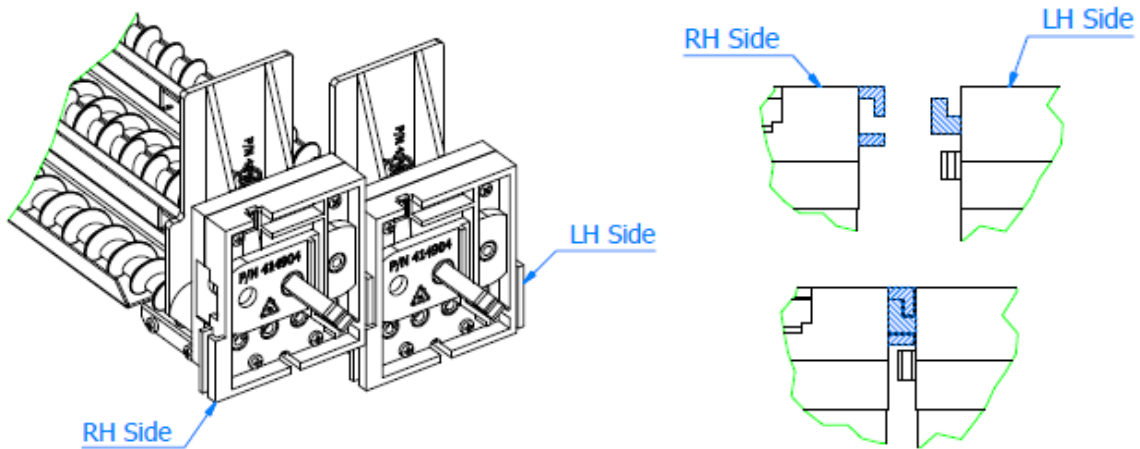
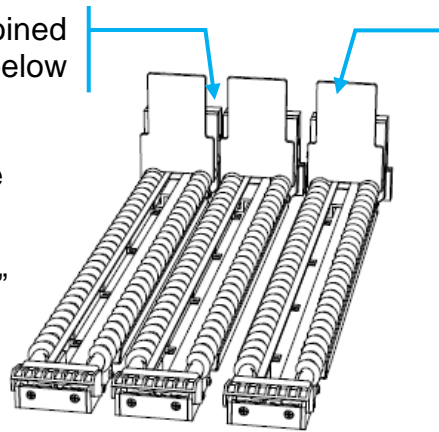

» Dual Version Installation

The dual version can only be installed in the slots available for dual STD spiral selections. (It is not possible to position the dual version in a position other than that indicated in the figure)

Each dual Rotary System must be connected to a STD motor and a return motor

Max 3 dual selections, shelf with 6 selections

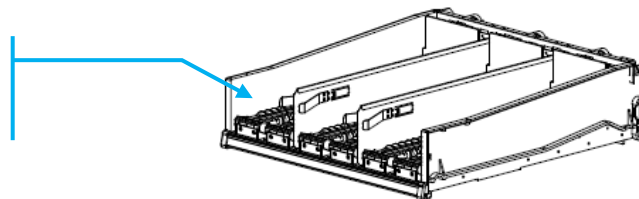

Max 4 dual selections, shelf with 8 selections

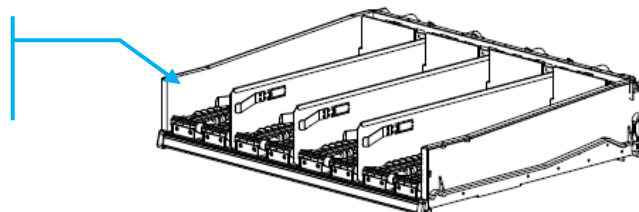

Max 4 dual selections, shelf with 8 selections

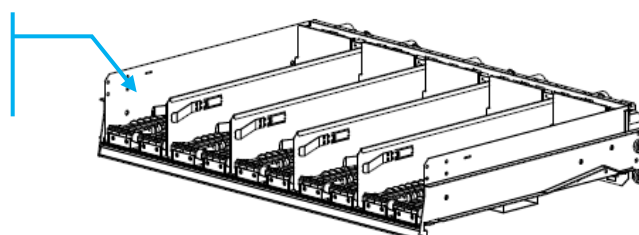

⚠ Attention!

Do not load products that are deformed or that have ears or various protrusions. This may cause problems when selling the product.

⚠ Attention!

Using the system, load the column with the relevant products for which the various software parameters are set up on software.

⚠ Attention!

We recommend only loading products with a flat bottom. Test that the products are delivered efficiently, before putting them on sale.

⚠ Attention!

When loading the product, position it centrally in relation to the selling mechanism. Loading the products randomly could block the products from sliding properly.

⚠ Attention!

When loading the products, make sure they do not scrape against the sides of the column, otherwise problems may occur during the product delivery.

4.2.4.4.1 Delivery type “Limit Switch”

» When this mode is set, the pusher continues to push the products until the limit switch has changed status twice (it activates and then deactivates, or deactivates and then reactivates).

When loading for vending:

» Load the products positioning the “Pusher” as close as possible to the last product loaded (to avoid waiting times that are too long when selling the first product, or failed deliveries) In this case, whether the limit switch is activated or not does not matter when the column is loaded.

We recommend leaving a gap of a few millimetres from the front of the vending mechanism, to avoid unwillingly dropping of the products.

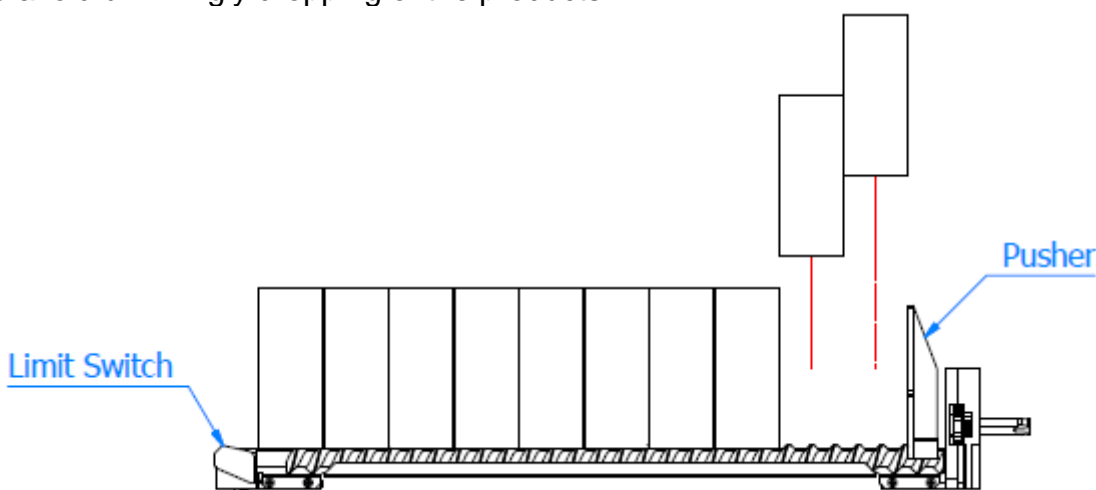

4.2.4.4.2 Delivery type “Step”

- » When this mode is set, the products loaded are delivered based on a step that must be calibrated using the relevant menu (Delivery step calibration). When the product is being delivered, pressure on the limit switch is not taken into consideration.
- » When this product delivery system is activated, the step for the products must be calibrated.

When loading for vending:

- » Load the products, positioning the “Pusher” as close as possible to the last product loaded (other wise delivery errors may occur due to the empty space that changes the step calculated by the vending machine)

In this case, whether the limit switch is activated or not does not matter when the column is loaded.

We recommend leaving a gap of a few millimetres from the front of the vending mechanism, to avoid unwillingly dropping of the products.

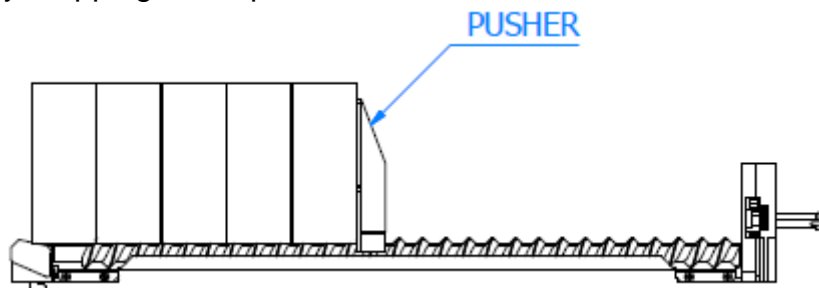

4.2.4.4.2 Delivery type “Step and Limit Switch”

- » When this mode is set, the products loaded are delivered based on a step that must be calibrated using the relevant menu (Delivery step calibration). When the product is being delivered, the first change of status on the limit switch, will adapt the step again for an optimum sale. Changes after the first in status of the micro switch, during the delivery time, calculated via the calibration, are not taken into account.
- » When this product delivery system is activated, the step for the products must be calibrated.

When loading for vending:

- » Load the products positioning the “Pusher” as close as possible to the last product loaded (to avoid waiting times that are too long when selling the first product, or failed deliveries)
- In this case, the limit switch must not be activated, do **NOT** position products on top of the limit switch.

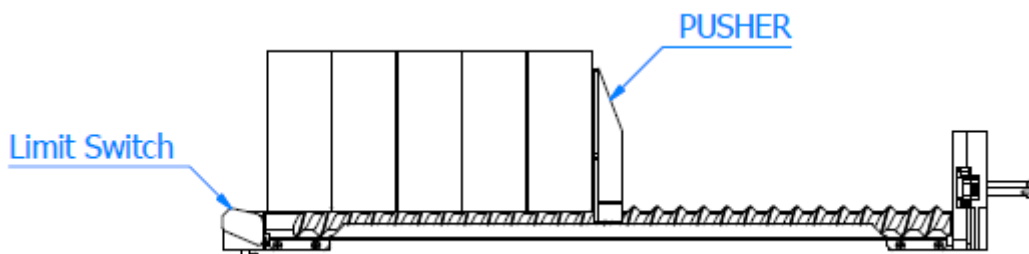

4.2.4.5 Spirals

From the following table it is possible to obtain the maximum dimensions, the number of distributable products, the pitch and the direction of the available spirals.

Spiral for Snack Shelf

Spiral		Diameter		Step	Product nr.
LH	RH	Ø64.5	Ø120		
■	■	■		11	42
■	■	■		18.5	24
■	■	■		25	17
■	■	■		30	14
■	■	■		35	12
■	■	■		45	10
■	■	■		55	8
■	■	■		65	7
■	■	■		85	5
■	■	■		40	11
■	■	■		77	6
■	■	■		95	4
■	■	■		105	4
■	■		■	120	4

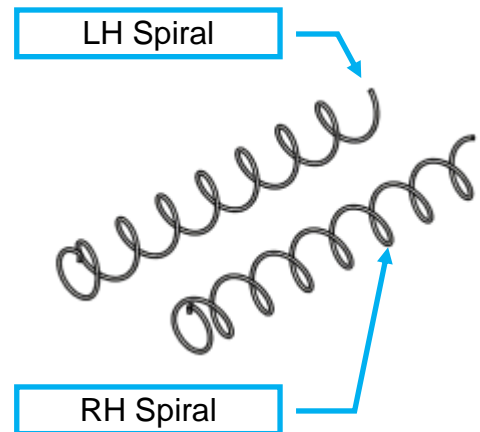

N.B. Check the spare parts manual for part numbers.

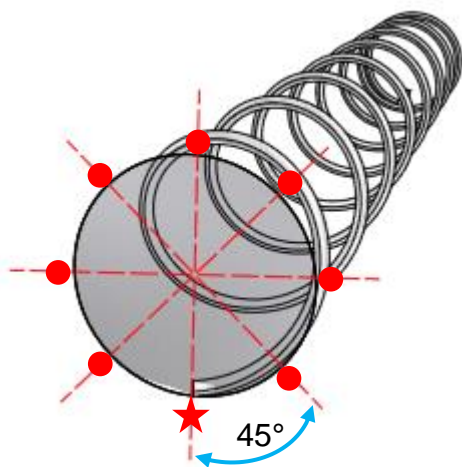
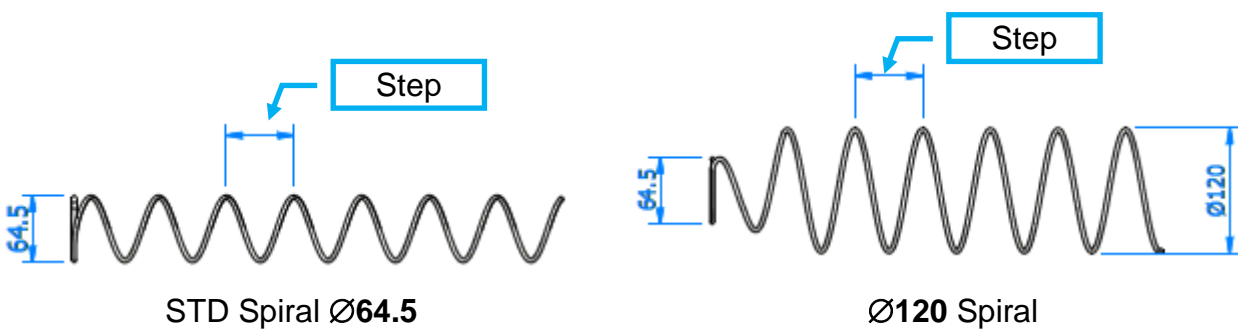

Normally the products are distributed without problems when the end of the spiral is positioned in the lower center.

The spirals can be positioned in steps of 45° by rotating them in the direction of expulsion.

4.2.4.6 Kit Sandwich

A special kit has been created to sell "Sandwich" products.

Using one of the available kits, it is possible to sell products with the following dimensions:

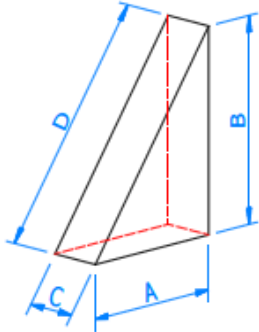

- A: from 120mm to 140mm
- B: from 120mm to 140mm
- C: from 70mm to 105mm (according to the depth you will have to choose the appropriate spiral)
- D: from 180mm to 200mm

In order to sell a higher range of products, three types of Sandwich Kits have been created:

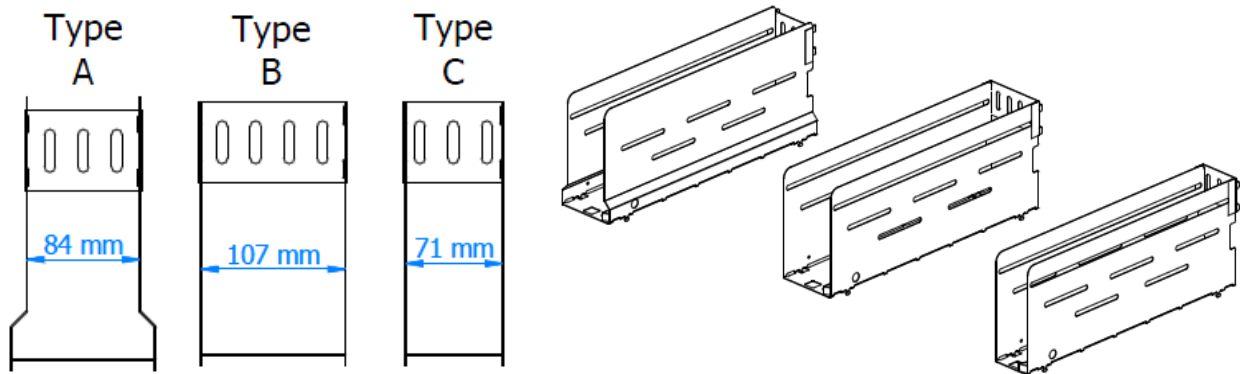

N.B. Check the spare parts manual for assembly part numbers.

4.2.4.7 Kit Baguette

The Baguette Kit was created to sell the particular products.

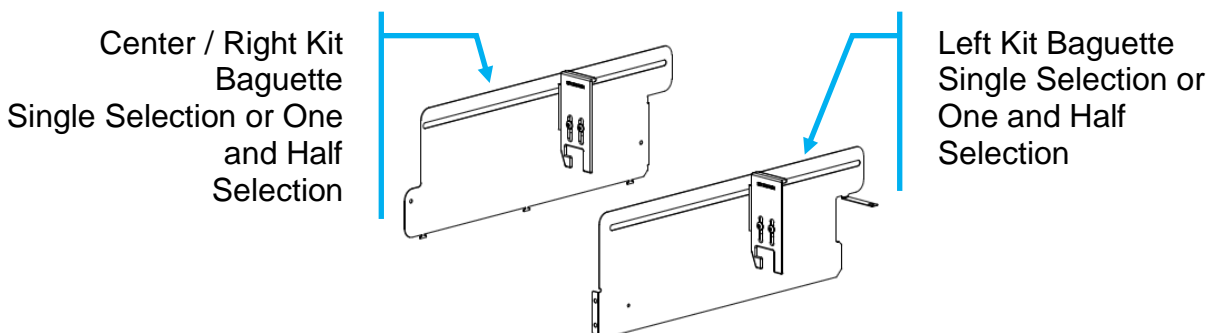

N.B. Check the spare parts manual for assembly part numbers.

4.2.5 Shelf Extraction / Removal

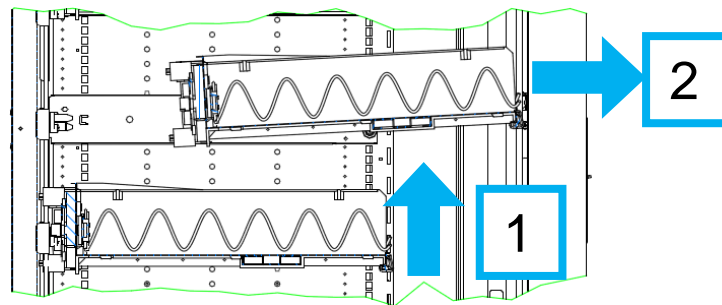

To remove the shelf proceed as follows:

- » Lift up the front of the shelf slightly;
- » Pull frontward the shelf until it stops, thus reaching the product loading position;
- » Lift up the rear of the shelf and pull outwards to remove it from the vending machine;
- » To install a new shelf follow the instruction backward;
- » When you put back the shelf inside of the vending machine make sure that the connection has taken place.

⚠ Attention!

- » When the vending machine has normal shelf, the lower one has the locking system installed.
- » When the vending machine has shelf with spiral $\varnothing 120\text{mm}$, the locking system must be installed on all of them.
- » When the vending machine has shelf guides for the greater inclination, the locking system must be installed.
- » On the models with ten selections all the shelves have the locking system.

4.2.5.1 Shelf guide

⚠ Attention!

- » Follow the instructions for setting up the machine to know at which heights to fix the guides.

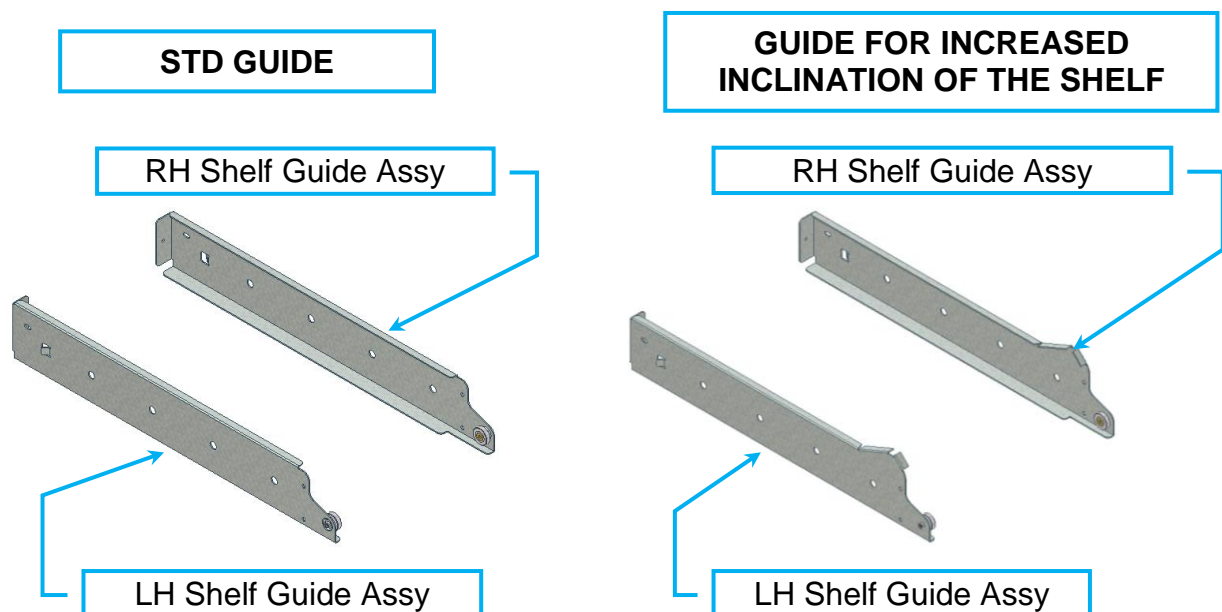

4.2.5.2 How to measure heights between shelf

The heights between the shelves that SandenVendo indicates on its settings are measured as follows:

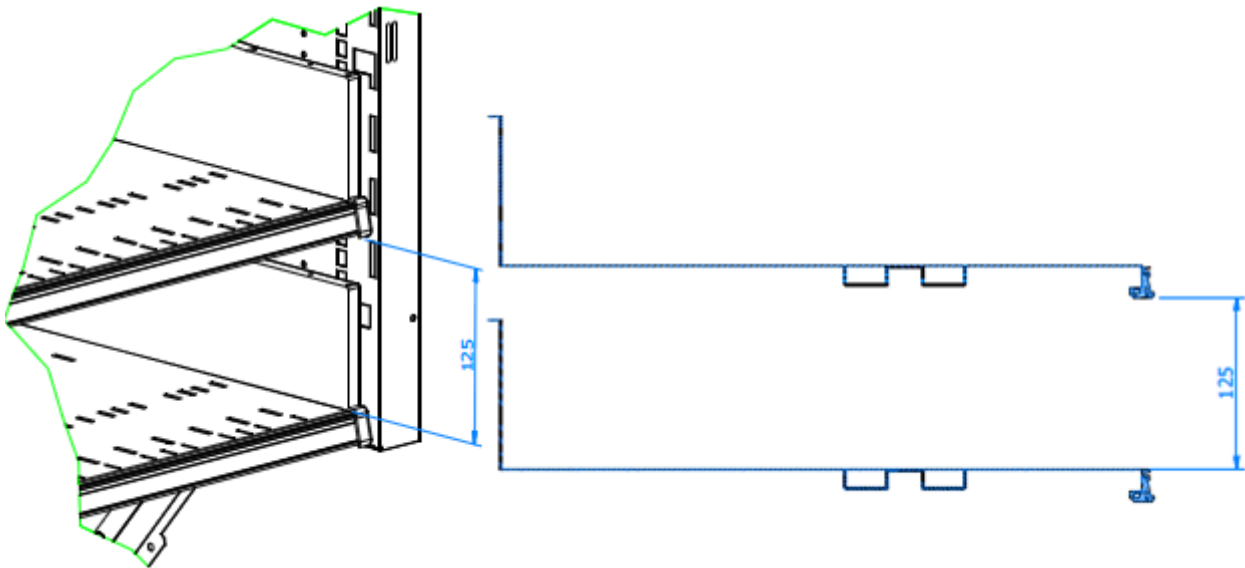

By inserting these measurements into the configurator, the number of holes to be used for fixing the guides can be calculated, as indicated in the following points.

4.2.5.3 Assembly / Disassembly of Shelf Guides

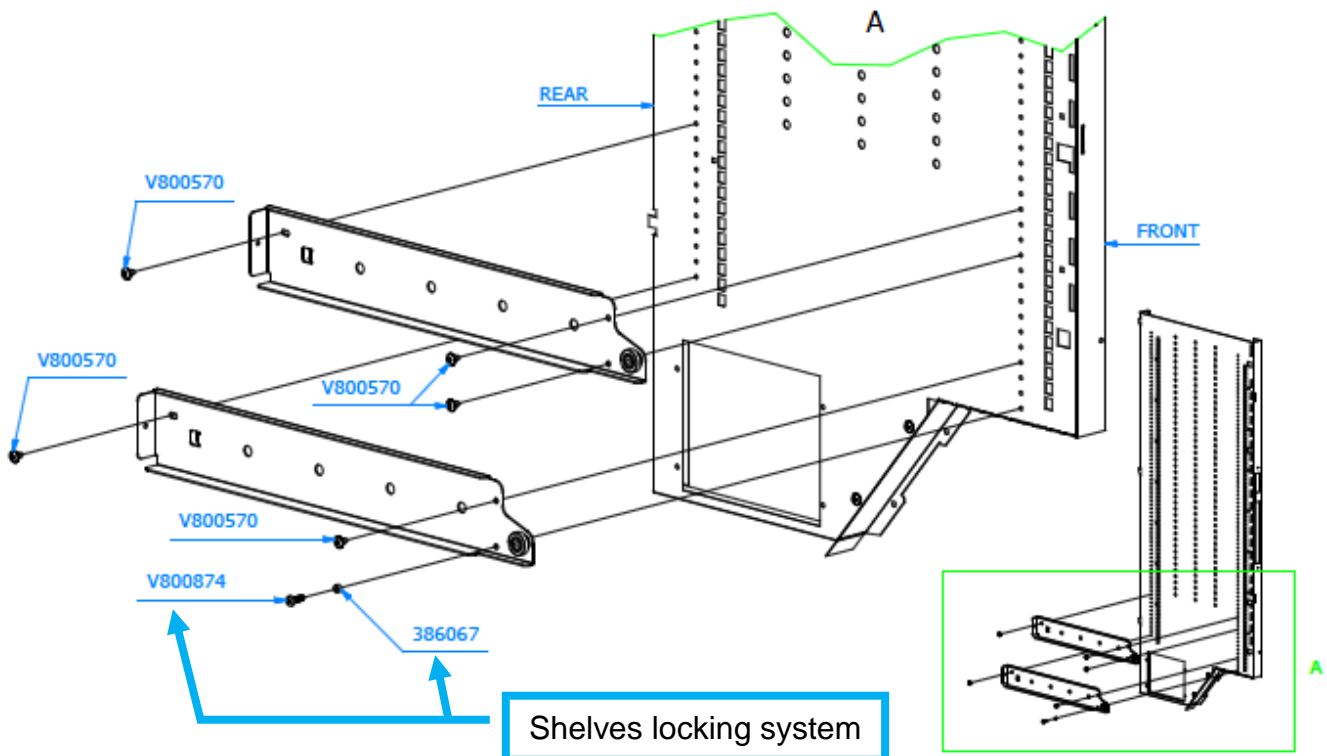

4.2.5.3.1 Change shelves height

The fixing holes are counted as shown in the following image:

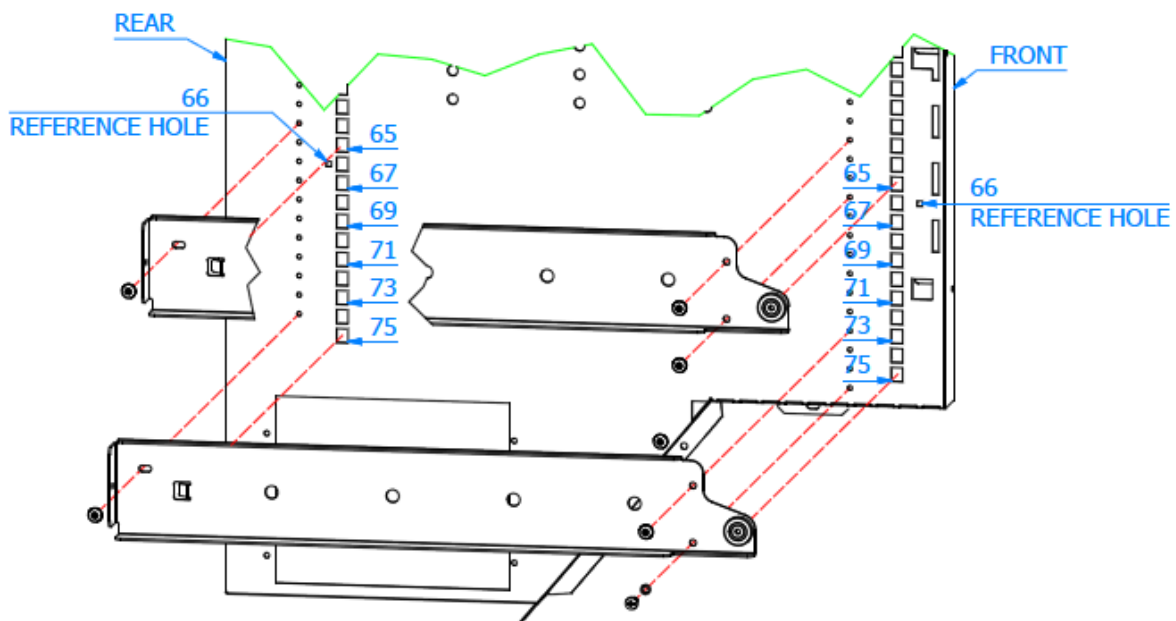
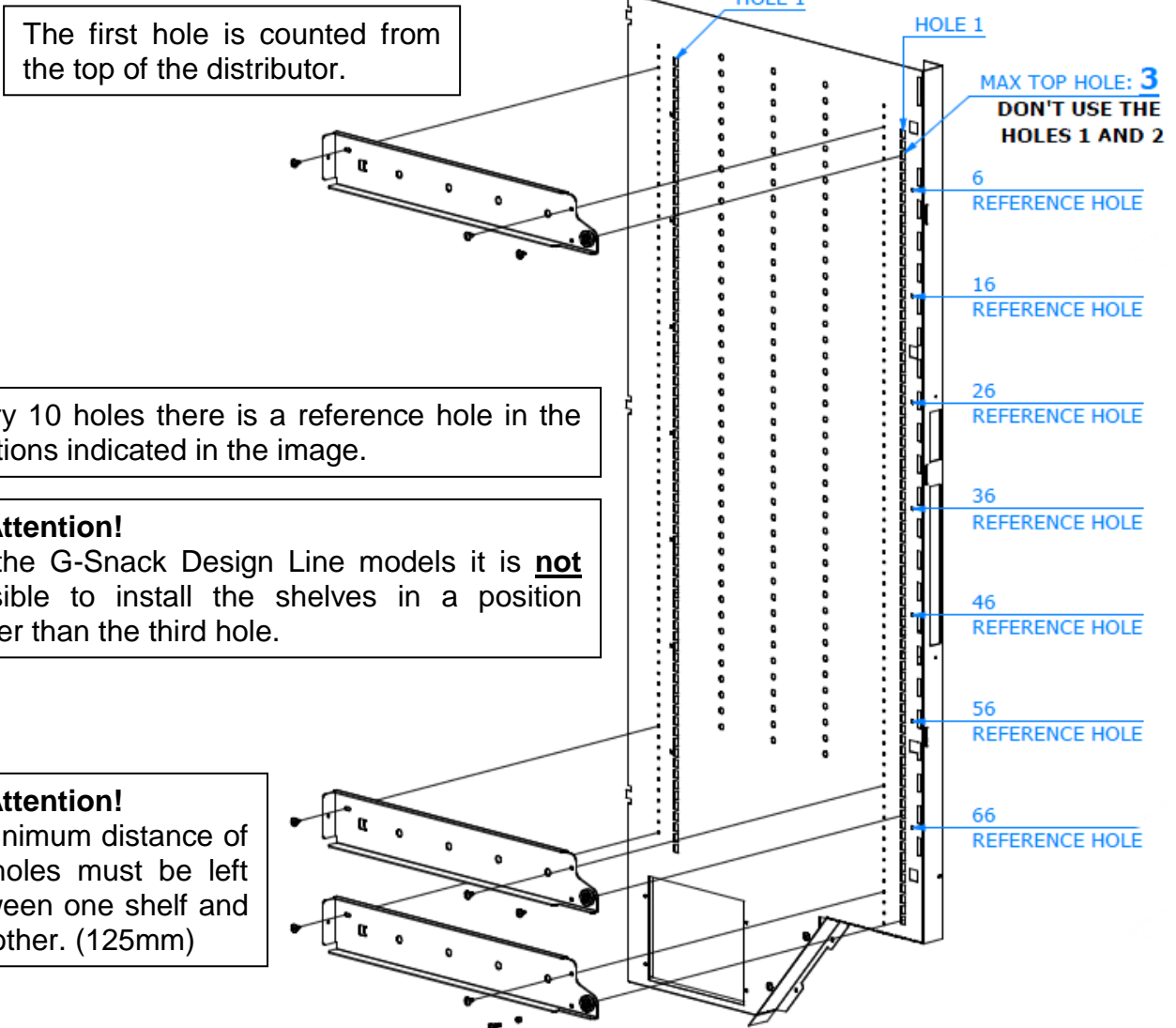

4.2.5.3.2 Assembly of Shelf Guides for E-Labeling Shelf

⚠ Attention!

» It is not possible to use the guides for greater inclination of the shelf when using the price bars.

⚠ Attention!

» On models with E-Labeling it is **not** possible to install the shelves in a position higher than the SIXTH hole.

⚠ Attention!

» A minimum distance of 11 holes must be left between one shelf and the other. ($\pm 130\text{mm}$)

Shelves with price bars need additional harness so the guide attachment differs slightly as shown below:

» Insert the harness p/n 144757 inside the catenary p/n 414021 before fixing it.

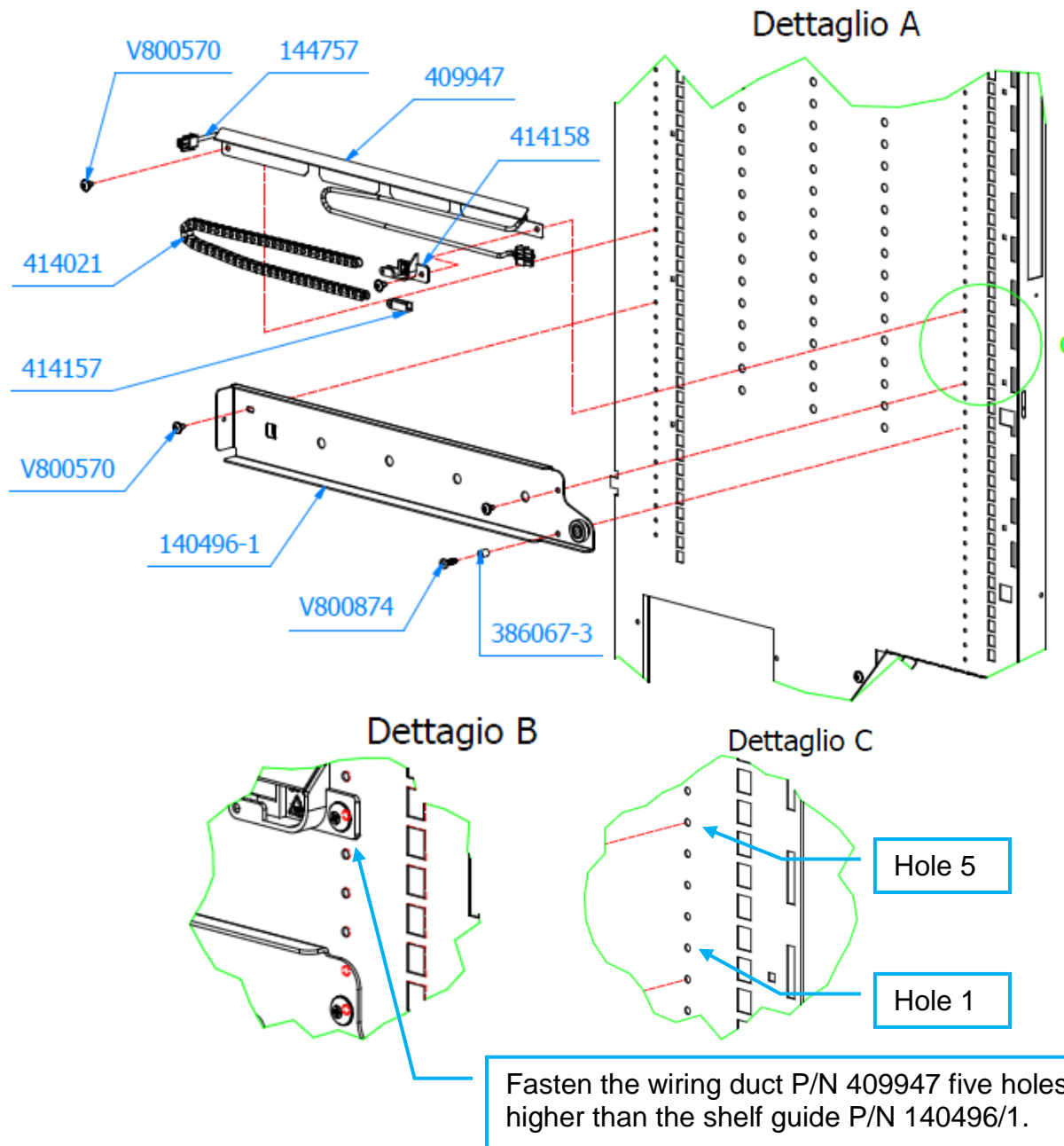

» After fixing the guide, connect the harness inside of the vending machine.

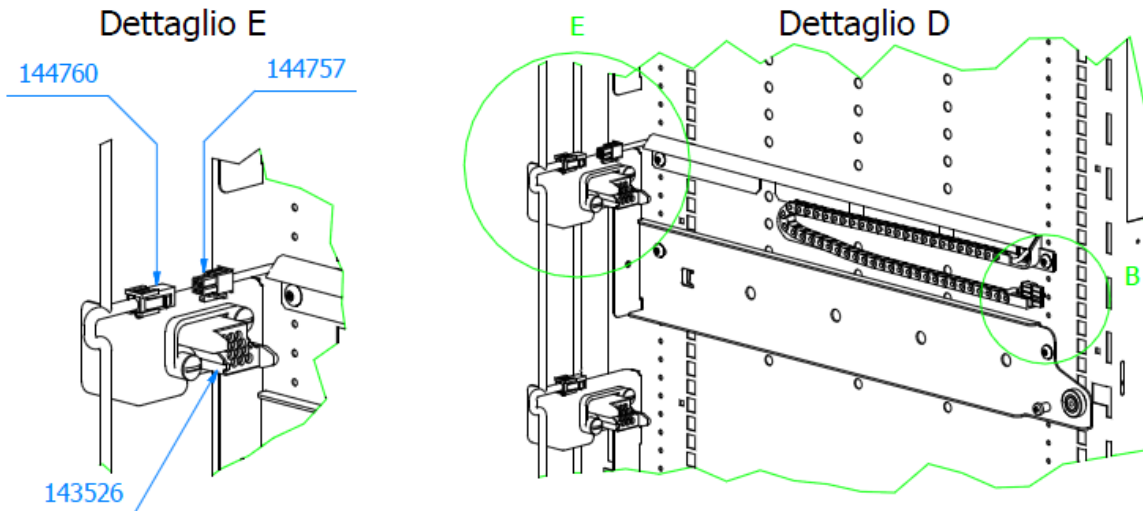

4.2.6 Configuration of the vending machine for 2 temperatures

The vending machine can be configured for 2 different temperatures inside the refrigerated cell, one for the sale of the food products (lower area) and one for the snack products (upper area).

The division of the two areas of temperature is done using two sheet deflectors that inserted inside the air channel delimit the height of the area to be cooled down, maintaining the desired temperature set on the electronic control unit.

The air channels situated inside the cell are practically the two side panels on which the supporting and sliding guides of the cassettes are fastened.

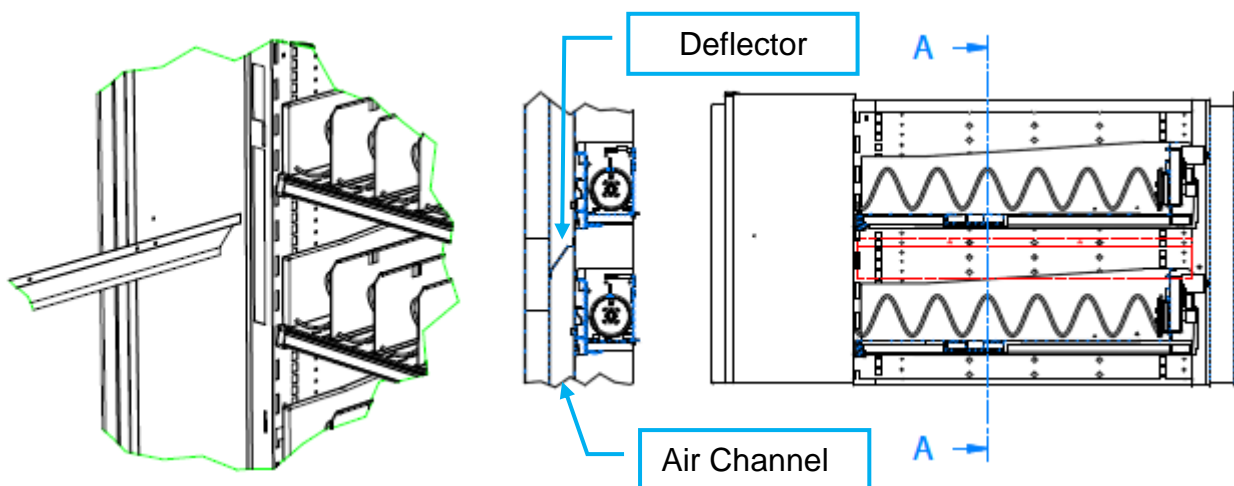

In this way, the chilled air from the cooling system that entered in the air channel is not able to pass through the deflectors, thus, define the cold area with controlled temperature (food area), which is the area under the deflectors, and upper area will have higher temperature (layered) for the sale of snack products.

Example: To have 2 lower cassettes for sale of fresh perishable products, place the 2 deflectors in the air channel, just below the cassette guide of 3rd cassette. To have 3 lower cassettes as “food” area, the deflectors should be placed just below the cassette guide of 4th cassette (see photo 4)

4.2.7 Elevator (optional)

The elevator is one of the options on the **G-Snack Design Line** models.

The elevator collects the product from the shelf and takes it to the delivery door on a tray, this avoids product being damaged when falling. The elevator has a rest position (called home position) which is at the top of its course.

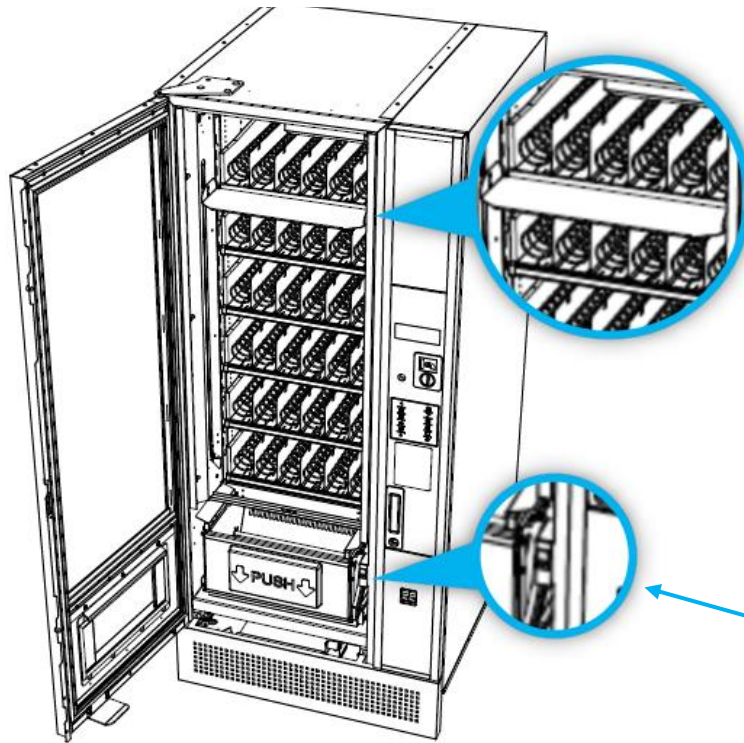

For safety purpose the elevator is inhibited through a push button switch that operates automatically when the door is opened.

The switch must never be activated while filling. It can only be activated for maintenance and only by qualified personnel.

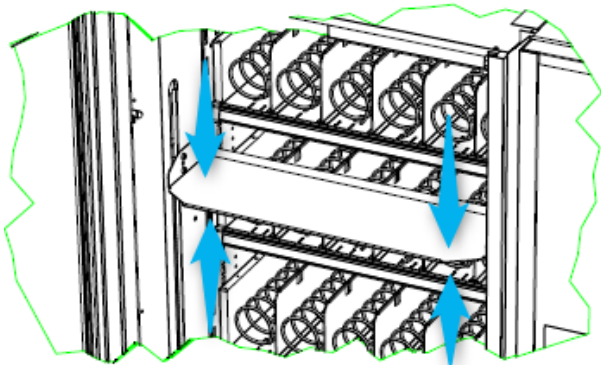

- » During the loading operations, or spiral or motor replacements on the cassette it is possible to use the elevator manually; the shelf position can vary according to the different needs.
- » Place the palms of each hand on the extremities of the elevator shelf and push or lift it delicately, until reaching the position to extract the drawer for loading.

» At the end of the loading operations, when the door is closed the switch will permit the correct supply to the motor and the elevator will automatically go to home position.

⚠ Attention!

During the insertion of the shelf inside the cabinet be careful of the connector plug.

⚠ Attention!

Some products, mainly bottles, could lean against the edge of the shelf.

In this case, it is sufficient to programme the stopping of the elevator at a lower level.

⚠ Attention!

Other products, mainly bottles, with length similar to the distance between the window and the shelf (around 200mm) could remain blocked in such space. The best solution, in addition to the one mentioned above, is to avoid selling the product with the elevator and place the products on the lower shelf.

⚠ Attention!

The space between the elevator and the shelf is very limited, the products in the spirals shouldn't stick out of the shelf, otherwise the elevator when passing could hook them up and stop.

The elevator has a sophisticated control of the current absorption and therefore damages are not produced, but the vending machine could go out of order.

⚠ Attention!

The space between the elevator and the shelf is very limited, this permits to sell even thin products with the elevator.

Obviously there are products that could drop in the space between the elevator and the shelf, the distributor still recognizes the sale, if it arrives inside the delivery eyelet.

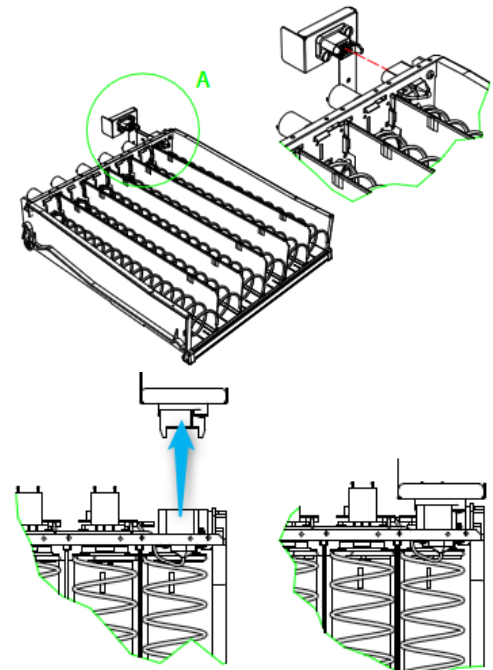

4.2.8 Motorized Locking for Delivery Eyelet (optional)

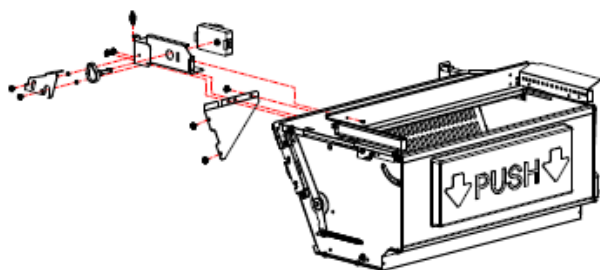

Among options of the models **G-Snack Design Line** is also available a "Motorized Locking for Delivery Eyelet" kit.

The kit, when installed and activated from the programming menu, locks the delivery eyelet until a selection is made.

Only after you have inserted the coin and made a selection, the motor of the kit releases the hook for a pre-set time.

During this period the delivery eyelet remains unlocked.

When time has run out, the motor rotates the cam and the hook is released.

When the door of the delivery eyelet is closed again, the kit locks it.

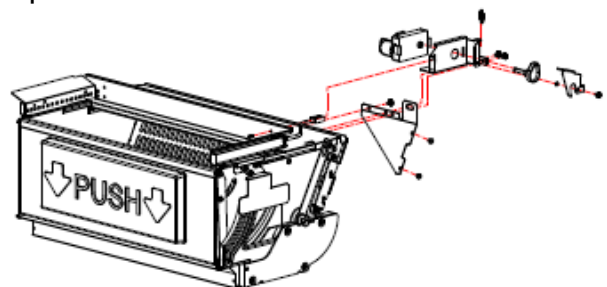

It is possible to choose on which side of the delivery eyelet to install the kit.

4.2.8 Refrigerant System Operation

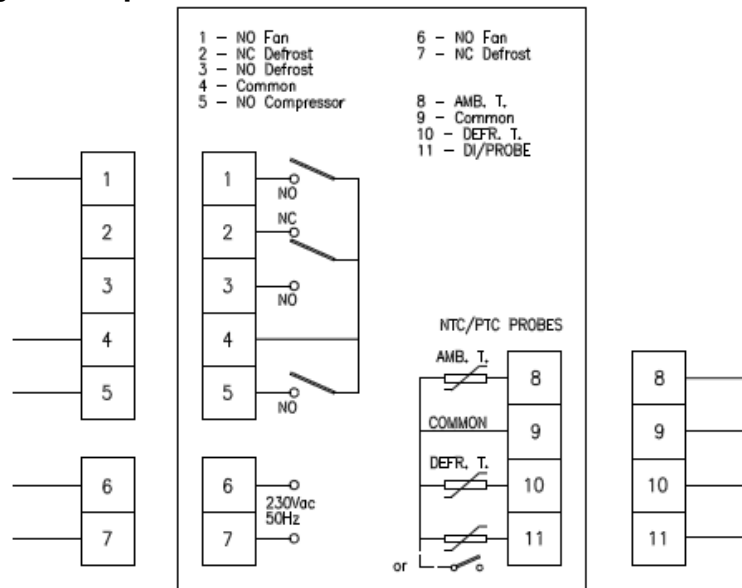

CONTROL UNIT COOLING

When switching on the control unit for the first times there will be a delay of three minutes in the compressor and evaporator fan starting .

During normal working, the compressor will stop only after reaching the set point temperature and the evaporator fans will work always.

When opening the door (if there is a door switch) both the compressor (if working) and fans will stop.

When closing the door, the fans will start immediately, while the compressor will have a delay of three minutes from the last switching off, even if the door is closed before.

The cooling unit is controlled by various parameters inserted in the software of the control unit and unchangeable by the User, this avoids possible and unwanted modifications to the same parameters, that could cause a malfunctioning of the cooling unit. In any case, for any particular needs it is possible to contact the technical assistance service that will assist you in various problems.

4.2.8.1 Description and function of Control Unit EASY CAREL

The electronic control unit EASY CAREL regulates and controls the refrigerant system and all its components: The compressor, the fans, the defrosting, and is independent of the control of the board SVE01, which control the electronics of the distributor.



On the front of the control unit are: 3 digits, 6 LED indicators that show the operating conditions and 3 buttons.

4.2.8.1.1 Display

1. Compressor LED
2. Fan LED
3. Defrost LED
4. Auxiliary exit
5. Watch
6. Alarm
7. Numbers

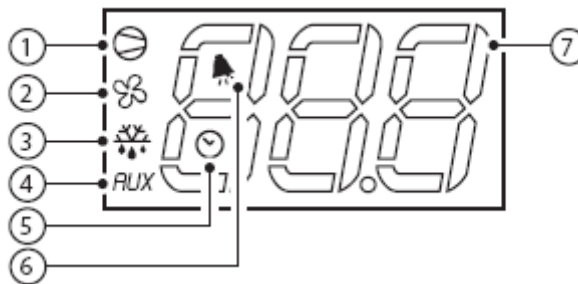

The LED light on the display show the operation of the cooling system.

- 1 Compressor LED: indicates the status of the compressor.
 - LED is lit, the compressor is ON
 - LED blinks, the compressor is waiting before starting (check ES)
 - LED OFF, the compressor is OFF.
- 2 Fan LED: indicate the status of the evaporator.
 - LED is lit, the fans are running
 - LED blinks, the fans are waiting before starting
 - LED OFF, The fans are turned off
- 3 Defrost LED: indicate the status of the defrost.
 - LED is lit, The defrost mode is ON
 - LED blinks, is in drip mode after defrost
 - LED OFF, defrost is OFF.
- 4 Auxiliary exit: not used in this vendor.

4.2.8.1.2 Keyboard

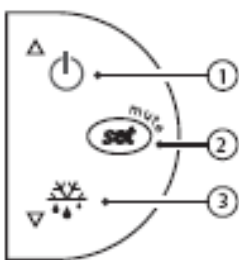

Key 1 "UP", in normal function if pushed for more than 1 second, it visualizes the temperature of probe 2 (evaporator). If pushed during the visualization of the set point it increases the set value.

Key 2 "SET", pushed more that 1 second allows the visualization and setting of the set point

Key 3 "DOWN", pushed for more than 3 seconds starts or stops the defrost, and if it is pushed during the visualization of the set point it decreases the set value.

4.2.8.1.3 Set the temperature

The setting of the internal temperature is performed via the control unit in the following manner:

Press for more than 1 second the button 2 "SET", the display show the set point temperature setting.

To increase or decrease the value press button 1 "UP" or 3 "DOWN".

Press button 2 "SET" to confirm the new value.

4.2.8.1.4 Quick defrost

You can start a defrost without changing the interval set on the controller.

If the gasket is damaged or the delivery door remains open too long (for example is blocked by an object) the hot air enters into the cold store thus creating ice above the evaporator which blocks the passage of air.

To solve the problem you need to initiate an additional defrost action that may be performed in a few steps:

To start the defrost press and hold for 3 seconds the button 3 "DOWN". To stop the process, press again the button 3 "DOWN".

4.2.8.1.5 Description of the main signals and alarms

The error codes are displayed on the display alternating with the temperature gauge.

ERROR	DESCRIPTION
ES	The compressor has a timing delay when starting, therefore the LED of the compressor on the display starts to flash.
E0	Still or flashing means an adjusting probe error: <ul style="list-style-type: none"> • probe not working, the probe signal is interrupted or in short circuit; • probe is not compatible with the instrument; The E0 alarm signal is stable if it is the only alarm present (the temperature value is no longer shown), it flashes if there are other alarms or if the second probe is shown
E1	Flashes evaporator probe error: <ul style="list-style-type: none"> • probe not working, the probe signal is interrupted or in short circuit; • probe is not compatible with the instrument;
EE	Visualized during functioning or activation Error in reading of the machine parameters. See memorised data errors.
EF	Visualized during functioning or activation Error in reading of the working parameters. See memorised data errors.
ED	The last defrosting finishes when exceeding the maximum time. The indication disappears if the next defrost is finished correctly.
DF	Defrosting in course: <ul style="list-style-type: none"> • it is not an alarm signal but an indication that the instrument is doing a defrosting.
DISPLAY BLINKS	The control unit display and all the LED's are flashing: <ul style="list-style-type: none"> • indicates that the door is open, or that the door switch is not working correctly • it is activated when the door remains open for more than one hours

4.2.8.2 Control Unit CAREL ir33

The electronic control unit CAREL ir33 regulates and controls the refrigerant system and all its components: the compressor, the fans, the defrosting and is independent of the control of the board SVE01, which control the electronics of the distributor.

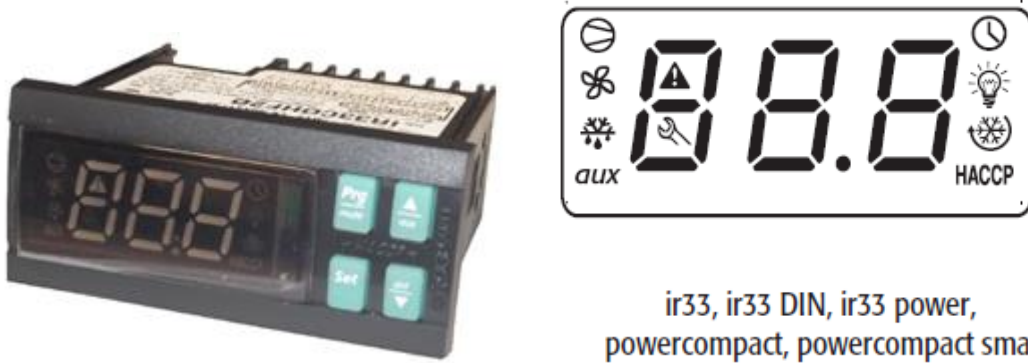

On the front of the control unit are: 3 digits, 7 LED indicators that show the operating conditions and 4 buttons.



ir33, ir33 DIN, ir33 power, powercompact, powercompact small

4.2.8.2.1 Display

ICON	FUNCTION	DESCRIPTION	Normal operation			Start up
			ON	OFF	BLINK	
	COMPRESSOR	ON when the compressor starts. Flashes when the activation of the compressor is delayed by safety times.	Compressor on	Compressor off	Awaiting activation	
	FAN	ON when the fan starts. Flashes when the activation of the fan is prevented due to external disabling or procedures in progress.	Fan on	Fan off	Awaiting activation	
	DEFROST	ON when the defrost is activated. Flashes when the activation of the defrost is prevented due to external disabling or procedures in progress.	Defrost in progress	Defrost not in progress	Awaiting activation	
AUX	AUX	Flashes if the anti-sweat heater function is active, ON when the auxiliary output (1 and/or 2) selected as AUX (or LIGHT in firmware version 3.6) is activated.	AUX auxiliary output active (version 3.6 light auxiliary output active)	AUX auxiliary output not active	Anti-sweat heater function active	
	ALLARM	ON following pre-activation of the delayed external digital input alarm. Flashes in the event of alarms during normal operation (e.g. high/low temperature) or in the event of alarms from an immediate or delayed external digital input.	Delayed external alarm (before the time 'A7' elapses)	No alarm present	Alarms in norm. operation (e.g. High/low temperature) or immediate or delayed alarm from external digital input	
	CLOCK	ON if at least one timed defrost has been set. At start-up, comes ON for a few seconds to indicate that the Real Time Clock is fitted.	If at least 1 timed defrost event has been set	No timed defrost event set	Alarm clock	ON if real-time clock present

ICON	FUNCTION	DESCRIPTION	Normal operation			Start up
			ON	OFF	BLINK	
	LIGHT	Flashes if the anti-sweat heater function is active, ON when the auxiliary output (1 and/or 2) selected as LIGHT is activated (in firmware version 3.6 it does not flash in anti-sweat heater mode and comes on when the dead band output is active).	Light auxiliary output on (version 3.6 dead band auxiliary output active)	Light auxiliary output off	Anti-sweat heater function active (version 3.6 does not flash in anti-sweat heater mode)	
	SERVICE	Flashes in the event of malfunctions, for example E2PROM errors or probe faults.		No malfunction	Malfunction (e.g. E2PROM error or probe fault). Contact service	
HACCP	HACCP	ON if the HACCP function is enabled. Flashes when there are new HACCP alarms stored (HA and/or HF alarm shown on the display).	HACCP function enabled	HACCP function not enabled	HACCP alarm saved (HA and/or HF)	
	CONTINUOUS CYCLE	ON when the CONTINUOUS CYCLE function is activated. Flashes if the activation of the function is prevented due to external disabling or procedures in progress (E.g.: minimum compressor OFF time).	CONTINUOUS CYCLE operation activated	CONTINUOUS CYCLE function not activated	CONTINUOUS CYCLE operation requested	
	DISPLAY	Shows temperature in range -50 to +150°C. The temperature is displayed with resolution to the tenths between -19.9 and + 19.9 °C. The display of the tenths can be disabled by setting a parameter.				

4.2.8.2.2 Keyboard



Icon	Normal operation		Start up	Automatic address assignment request
	pressing the button alone	pressing together with other buttons		
<p>Prg mute</p> <p>PRG/MUTE</p>	<p>If pressed for more than 5 seconds, accesses the menu for setting the type "F" parameters (frequent). Mutes the audible alarm (buzzer) and deactivates the alarm relay</p>	<p>PRG+SET: if pressed together for more than 5 seconds, accesses the menu for setting the type "C" parameters (configuration) or downloading the parameters. PRG+UP/AUX: if pressed for more than 5s, resets any alarms with manual reset</p>	<p>If pressed for more than 5 seconds at start-up, activates the procedure for restoring the default parameters</p>	<p>If pressed for more than 1 second, starts the automatic serial address assignment procedure</p>
<p>▲ aux</p> <p>UP/AUX</p>	<p>If pressed for more than 1s, activates/deactivates the auxiliary output.</p>	<p>UP/AUX+DOWN/DEF: if pressed together for more than 5 seconds, activates/deactivates continuous cycle operation. UP/AUX +SET: if pressed together for more than 5 seconds, starts the report printing procedure (if the controller is connected to the printer interface). UP/AUX +PRG/MUTE: if pressed together for more than 5 seconds, resets any active alarms with manual reset.</p>		
<p>▼ def</p> <p>DOWN/DEF</p>	<p>If pressed for more than 5 seconds activates a manual defrost</p>	<p>DOWN/DEF +UP/AUX: if pressed together for more than 5 seconds activates/deactivates continuous cycle operation. DOWN/DEF +SET: if pressed together for more than 5 seconds, displays a sub-menu used to access the parameters relating to the HACCP alarms ('HA', 'HAN', 'HF', 'HF_n').</p>		
<p>Set</p> <p>SET</p>	<p>If pressed for more than 1 second, displays and/or sets the set point.</p>	<p>SET+PRG/MUTE: if pressed together for more than 5 seconds accesses the menu for setting the type "C" parameters (configuration) or downloading the parameters. SET+DOWN/DEF: if pressed together for more than 5 seconds, displays a sub-menu used to access the parameters relating to the HACCP alarms ('HA', 'HAN', 'HF', 'HF_n'). SET+UP/AUX: if pressed together for more than 5 seconds, starts the report printing procedure (if the controller is connected to the printer interface).</p>		

4.2.8.2.3 Displaying and setting the set point

Press **SET** for more than 1 second to display the set point;
Increase or decrease the set point using the ▲ or ▼ buttons respectively, until reaching the desired value;
Press **SET** again to confirm the new value.

5 MAINTENANCE

5.1 Warnings

According to current health regulations, the operator of a vending machine is responsible for hygiene and cleanliness of the same.

The following section is a basic guide for the general maintenance and cleaning of the vending machine. Maintenance on the cooling unit may only be performed by trained specialist staff. While working, always wear protective goggles and gloves. Maintenance personnel must be made aware of the potential danger in touching hot metal parts. Even with the power off all the components of the cooling machine may still be very hot, especially touching the evaporator heater may cause burns.

Before carrying out any cleaning operation on the vending machine, pay careful attention to the following directions:

- Perform electrical insulation of the vending machine before cleaning or when an electrical component is connected / disconnected.
- Do not use blades or other sharp tools to scrape parts or components in the vending machine.
- Do not clean the vending machine in direct sunlight or in high temperatures.
- Cut off the power supply before cleaning electrical parts and/or parts protected by covers.
- The power plug must be positioned so that the operator can see and control it from any position.
- Do not use cleaning products other than those recommended.
- All types of cleaning that require the use of liquids should only be carried out after disconnecting the machine from the mains power supply.
- Never use pressured water cleaner or water jets.
- Never clean with blades or pointed objects.

Attention!

SandenVendo declines all responsibility for damage caused by failure to observe the precautions contained in the manual and the current regulations.

5.2 Recommended cleaning products

We recommend cleaning the machine using only the following types of products and materials:

- neutral detergent
- compressed air (2 bar max.)

Attention!

In order to avoid any oxidization, corrosion, brattling, peeling of paint and other damages to the machine **NEVER USE** under any circumstance the following products::

- abrasive detergents
- very alkaline or acidic detergents
- benzene
- petrol
- acetone

5.3 Cleaning safety devices

For each cleaning operation, it is advisable to wear protective gloves and/or clothing.

Attention!

Follow all cleaning product instructions and read the relevant COSHH data.

5.4 Preventive maintenance

To guarantee the machine operates correctly we recommend that you periodically carry out the following maintenance operations:

- Check the vending machine and the surrounding area, check for signs of rust on the outer cabinet and obstructions in the air vents.
- Open the door and check there is no accumulation of water, signs of rust, and humidity around the corners.
- Check that the evaporator outlet is not blocked (condensed water in the evaporator must drain out towards the condenser pan).
- Periodically check the door seals. Should they be damaged, replace the seals immediately.
- Periodically check that the condenser is clean.
- Check that the evaporator fan and the cooling system work normally (the fan blades must be free from any foreign matter).
- Check that the compressor and the condenser fan work normally (the fan blades must be free from any foreign matter).
- Check that all the selections are correctly delivered.
- Periodically check the service cord. If the cable or connector is damaged or worn, it must be replaced with a service cord of the same type as the original delivered together with the vending machine.

5.5 Cleaning operations

The vending machine should be generally cleaned in order to keep it in perfect working order.

In general, we advise following maintenance plan:

Attention!

Disconnect the vending machine from power supply before cleaning.

5.5.1 Daily Cleaning

- » Clean the decal using suitable detergents.
- » Clean the control panel using a damp cloth.
- » Clean the delivery area with a clean cloth.
- » When loading new products, check the expiry dates and load new products with the "FIFO" concept (first in - first out, that is: first inserted - first extract).
- » Remove dust and / or dirt from the sensors using compressed air and / or a clean cloth.

5.5.2 Weekly Cleaning

In addition to the daily cleaning operations:

- » Clean the ventilation grate using compressed air and a damp cloth.
- » Clean the shelves using warm water and neutral detergents. Be careful not to get the electrical parts on the motors wet. Do not use solvents or abrasive cleaners.
- » Check for insects and remove them if necessary from inside the vending machine.
- » Remove the dust generated in the area of the refrigerant system, especially on the base.
- » Check the door seals, clean using lukewarm water, non-abrasive detergents and a soft cloth. Do not lubricate the seals and check for deformation or damage. If necessary replace..
- » Check and clean the sensors of the installed payment systems. Refer to the manufacturer's instructions for each device.

5.5.3 Monthly Cleaning

In addition to the daily and weekly cleaning operations:

- » Clean the cabinet inside and outside using a suitable detergent or soap. Externally apply any good car wax. Repair any paint scratches to prevent corrosion.
- » Check the drain hose and clean. The water from the evaporator must flow freely in the tray next to the compressor.
- » Clean the display screen and the inside of the display panel.
- » Check and clean the LED bars using only warm water.
- » Check that all the compartments and pipes of the refrigerant system are clean and that there are no obstructions for the passage of air. Condenser and evaporator must be kept clean for optimal operation. Clean the condenser every three months with a vacuum cleaner and a brush, make sure that all the fins and hoses are free and clean.

5.5.4 Yearly Cleaning

In addition to the daily, weekly and monthly cleaning operations:

- » If necessary recharge the refrigerant system gas.
- » Check the integrity of the vending machine and the compliance with the standards of the relative systems by qualified personnel.
- » Remove all shelves, and the cooling system. Thoroughly clean all the components of the shelves, the refrigeration system and the inside of the vending machine. Reassemble all the components inside the cabinet. Bring the temperature to normal and load the desired products.

5.6 Assembly / Disassembly for Maintenance



Attention!

All the operations indicated in the following paragraphs (5.6.1, 5.6.2, etc.) must be carried out by qualified personnel.



Attention!

Contact technical assistance to request further support for any difficult operations.

5.6.1 LED Replacing

To replace the LED tubes, proceed as follows:

- » Open the vending machine door;
- » Turn off the vending machine from the main switch;
- » Disconnect the wiring of the LED tubes on the inner part of the door around the delivery area;
- » Through the hole on the inner part of the door: replace the desired LED tubes;
- » Connect the new LED tube..

Once the replacement operations have been completed, proceed as follows:

- » Turn on the vending machine from the main switch.
- » Close the door.

NOTE: with the door open, the LEDs turn off automatically.

5.6.2 Door Gasket Replacement

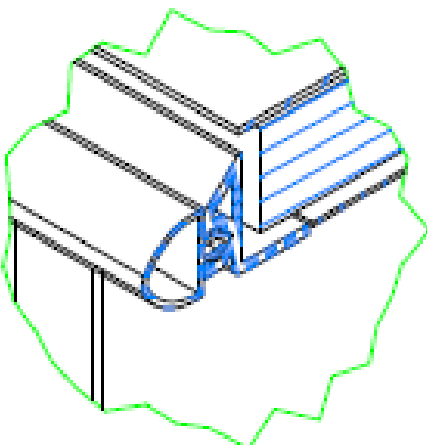

- » Open the vending machine drawer and door;
- » Pull the damaged gasket firmly until it is removed from the seat in the side profiles;
- » Insert the new gasket in the seat on the door profiles;
- » Fit the gasket well even in the corners, where it will be more difficult.



The gasket is fixed interlocking in the profiles on the door.

5.6.3 Spiral replacement

To replace the spirals proceed as follows:

- » Extract the shelf concerned (removal from the machine is not necessary);
- » Rotate the spiral counterclockwise until the two red (or black) hooks on the motor engagement match the slots of the spiral hook;

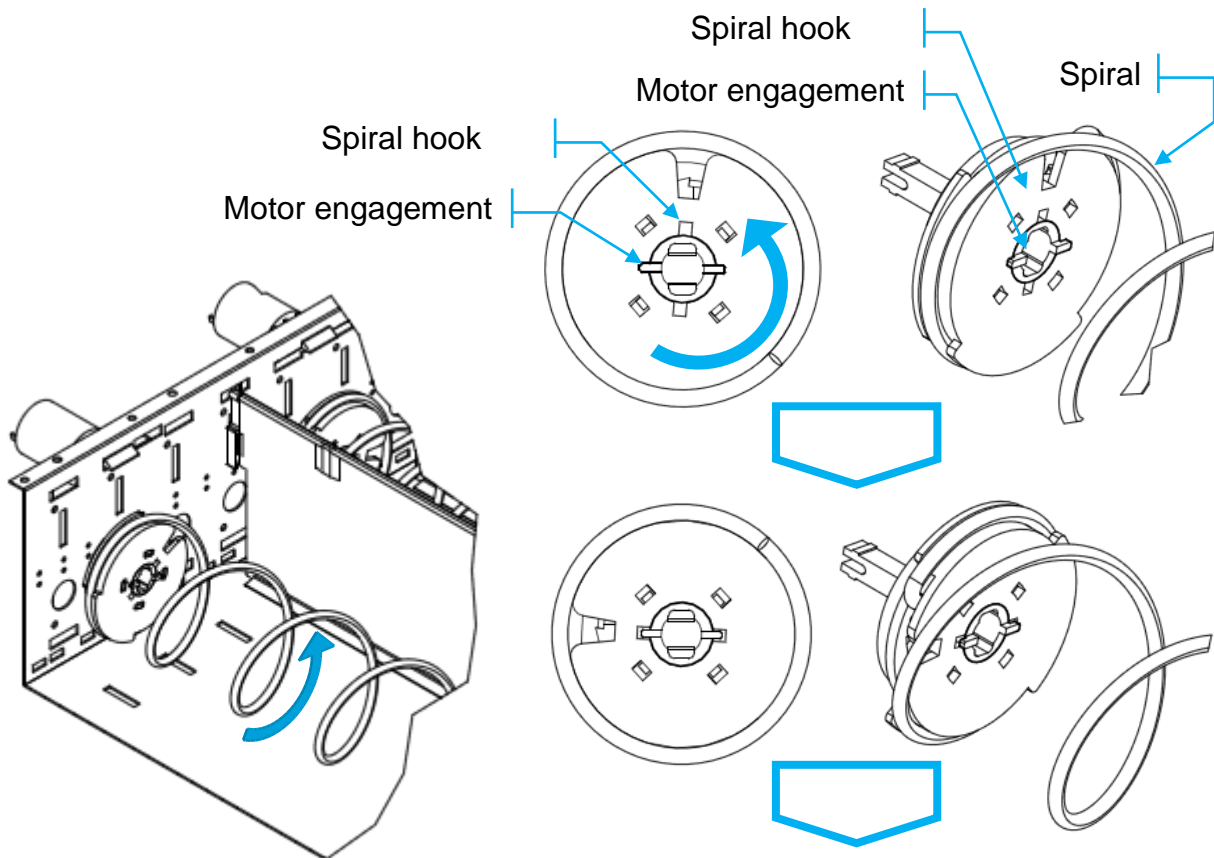

- » Extract the spiral with the spiral hook (white) by pulling forward;

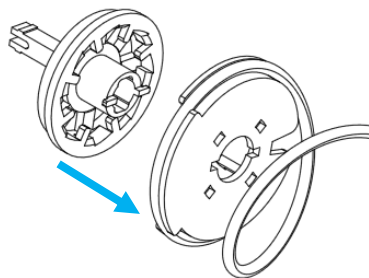

- » Hold the spiral hook (white) and release the spiral by turning it to the right or left, depending on where it is hooked.

- » Fix the new spiral over the spiral hook (white), in the same position as the previous spiral, and refit on the machine.

To hook the spiral into the empty column follow the previous instructions in reverse.

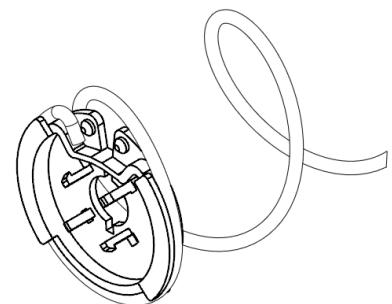

6 TROUBLESHOOTING

The following table lists the problems that may occur on our vending machines. We have listed the possible causes together with the recommended solutions to eliminate the problems.

Attention!

In case of failure and/or poor cooperation only contact the skilled personnel at our service centers.

Attention!

Check the programming manual to know the meaning of the errors shown on the display.

6.1 Door Errors

Problem	Possible causes	Recommended solutions
It is difficult to close the door or it does not close	vending machine crooked	Check that the vending machine is level, adjust the position by unscrewing / screwing the feet.
Condensate glass	Worn gasket	Check door gasket, and replace if necessary.

6.2 Cabinet Errors

Problem	Possible causes	Recommended solutions
LEDs do not light up	No power supply	Check if the vending machine is properly powered.
	Harness disconnected	Check connection of LED connectors.
	Defective LEDs	Replace.
Coin Return Motor not working	Faulty harness	Check harness connections
	Defective Motor	Replace
	Wrong motor height	Position the coin return motor at the correct height
SVE01 board without power supply	Transformer box	Check harness connections Check fuses Check socket
Does not enter the programming mode	Wiring connections of the SVE01 board	Connect harness properly. Replace card.
Defective display	It won't turn on	Check harness connection. Replace Display.
The vending machine is out of order and the display does not turn on	The fuses that protect the vending machine from short circuit are blown	Check the parameters of the electric current used. Look for the cause of the short circuit, check the power supply harness and the components of the transformer box. Replace the fuses on the transformer box.

Problem	Possible causes	Recommended solutions
The lock does not open	Wrong key	Make sure to use the key with the same encryption as the lock
	Lock stuck	With the door closed: It is necessary to drill the lock to be able to remove it. With the door open: Replace.
	Distributor not on the bubble	Straighten the distributor.
	Broken key inside the lock	Replace
Drawer closed but the machine does not go into sales mode.	Micro is not activated	Check if the micro on the right side of the cabinet is pressed correctly.
	Micro defective	Check if the micro is activated using the special key, replace if necessary.
	Faulty harness	Check the harness connections and their integrity.
Coin Return blocked	Dirty or stuck	Remove objects that block movement and / or clean.
Coin return button problems	Coin return motor not working	Check harness connections / integrity. Replace motor.
Date and time are not kept in memory after the vending machine is turned off and on	Battery on the SVE01 board exhausted	Replace battery on the board with an identical one
Error message "Lift communication error"	Communication error between the elevator and the board	Check harness connections / integrity.
Error message "Lift movement error"	Error detected if the elevator has some malfunction	

6.3 Payment Device Errors

Problem	Possible causes	Recommended solutions
Coinmech does not accept coins	No energy comes to the vending machine	Connect the plug, check the power outlet.
	Energy does not reach the coinmech	Check that the coinmech harness is not defective and that the fuse is not blown (consult the coinmech manual)
	The coinmech is out of order or the coin return lever is not pressed properly	Check the position of the coin return mechanism.
	Dirty coin channel	Clean the coinmech with an appropriate detergent. Dry very well.
	Defective coinmech	Replace coinmech
	Coin locked in the mechanism of the coinmech	Remove jam and test.

Problem	Possible causes	Recommended solutions
Coinmech does not accept coins	Coin return activated	Adjust coin return lever position.
	Vending machine in "Service Mode"	Vending machine door open or defective switches.
	The coin acceptor only accepts an amount of coins higher than the sale price	Check payment parameters as indicated in the programming manual.
	The coin acceptor only accepts one coin	Check the payment parameters. Check power supply malfunctions.
	The coin validator does not reset or does not receive signals from the acceptor.	Check integrity of harness, coinmech connections and, if necessary, the coinmech manual.
	Price set to 0 "zero"	Set the desired price
Coinmech does not return coins	Energy does not reach the coinmech	Check that the coinmech harness is not defective and that the fuse is not blown (consult the coinmech manual)
	There are no coins in the tubes	Fill the tubes with some coins.
	Pipes programmed the wrong way	Reprogram the tubes as indicated in the coinmech manual
	Defective coinmech	Replace coinmech
Banknote reader does not work	Prices / coin tubes settings	Check coin tubes
Banknote Reader does not accept banknotes		Check the banknote device manual or replace it.
	Insufficient coins in the tubes of the coinmech	Check payment settings, fill the coinmech tubes.
Banknote reader takes the banknote but does not release the credit.	Card, Harness and Banknote Reader	Check the banknote reader manual or replace. Check the harness. Replace the card.
No rest is returned	There are no coins in the coinmech	Load coins into the tubes of the coinmech.
Return wrong rest	Sale price set different from labels	Set correct price or replace labels
	Coinmech defective	Replace

6.4 Refrigerant System Errors

Problem	Possible causes	Recommended solutions
Error message "HACCP error"		Check the correct setting of the parameters of HACCP and check the correct operation of the refrigerant system.
The cooling system does not work.	No power to the vending machine.	Check the power source. Check the power cable connections and fuses.
	Door switch is not activated.	Check door closing and function of the door switch
	Temperature controller is defective or has a connection problem	Check the temperature controller and the connections
	Temperature controller is defective	Replace the temperature Controller
The compressor works, but the temperature is not ideal	The condenser is dirty.	Check if the condenser fins are dirty or obstructed. Clean using a small hard bristle hand brush.
	Machine is installed too close to the wall	Make sure that there is 10 cm space between the rear grid and the Wall
	The condenser fan does not work.	Check if the fan is blocked. Check the circuit. Replace the motor.
	The evaporator fan does not work.	Check the circuit. Replace the motor and check that the fan is not blocked. Check the fan relay, check the connection to the temperature controller
	The temperature setting is not correct.	Set the desired temperature (ref. Programming Manual).
	Not enough refrigerant in system.	Replace cooling unit
Evaporator covered in ice.	Evaporator fan does not work.	Check the circuit. Replace the motor and check that the fan is not blocked. Check the fan relay, check the connection to the temperature controller
	The cooling compartment is badly sealed.	Change the sealing and/or adjust the internal door closure. Check that the product delivery door is closing correctly after product delivery .

Problem	Possible causes	Recommended solutions
The compressor runs, is warm but no cold is	Check the end of the capillary tube	If no ice is produced after 5 minutes function, there is a refrigerant leakage. Replace the cooling unit.
When the vending machine is turned on, the system does not start immediately	Operation set to not cause damage to the system.	Wait about three minutes.
The compressor does not start	there is no electricity	Distributor is not connected to the power supply
	Fuses of transformer box blown	Replace
	Service cord Damaged	Replace
	Power supply not compliant with the indications on the vending machine plate	
	Faulty relay	Check relay
Overload compressor	Wrong voltage	Check if the power supply reflects the data indicated on the vending machine plate
	Faulty relay, does not open after startup	Check the relay
	Short circuit in other components	Insulate and eliminate expensive electrical components until you find the short.
	Hot compressor	Dirty condenser. Problems with the motor or condenser fan. Insufficient ventilation.
System vibrates or is noisy	Various components touch each other	Check fans and motors. Clean any dirt. Loose sheets or wiring, loose screws.
	Aged or worn elbow	
	Low voltage	
	Damaged valves	
Short work cycles	Temperature sensor defective or installed in the wrong place.	Check wiring and sensor integrity. Check sensor position.
	Defective control unit	Replace
	Temperature set too hot	Check paragraph on how to set the control unit.
System remains in operation for a long time or continuously	Defective temperature sensor or mounted in the wrong place	Check integrity of harness and sensor. Check sensor position.
	Defective relay	
	Not enough air circulation	Check the ventilation grid

Problem	Possible causes	Recommended solutions
System remains in operation for a long time or continuously	Door gasket does not seal properly	Check gasket and replace if necessary.
	Charged hot products. After the filling of the vending machine, the refrigeration system takes longer to lower the temperature of the products.	
	Short circuit of the refrigerant system or its components	
	Defective control unit	Replace
	Ambient temperature and relative humidity higher than those indicated for standard operations.	
	Lack of gas in the cooling system due to some leaks.	
	The fans do not allow the air to circulate inside the distributor	Check the ventilation channels of the distributor.
Temperature too cold	Defective temperature sensor	Check integrity of harness and sensor.
	Temperature set too cold	Check paragraph on how to set the control unit.
	Defective relay	
	Defective control unit	Replace
Temperature too high	Defective temperature sensor	Check integrity of harness and sensor.
	Temperature set too hot	Check paragraph on how to set the control unit.
	Defective relay	
	Defective control unit	Replace
	Faulty evaporator motors causing pipes to freeze	
	Insufficient ventilation of the condenser, for various reasons (dirt, fan jamming, faulty motors)	Check the ventilation channels and remove any obstructions.
	The vending machine is positioned too close to the wall	Make sure there is at least 10cm of space between the rear grill and the wall.
	Defective compressor valves	Replace

6.5 Shelf Errors

Problem	Possible causes	Recommended solutions
The motor of the selection does not work	The motor was overloaded and went out of service.	Check the operation of the motor with the test menu. Check the set up of the selections and the step of the spirals.
	The motor has not been assigned to a selection.	Carry out the "spiral detection" as indicated in the programming manual.
	Connection problems	Check the motor connections
	The presence of the motor is not detected	Check the harness connection. Check the motor.
	The motor not working	Replace the motor.
The spiral rotates more than once	The product has not been dispensed	Setting activated through the menu, check programming manual
	The dispensed product was not detected by the optical barrier.	Check the optical barrier. Check harness of the optical barrier. Replace the optical barrier.
	Faulty of spiral motor	Replace the motor
	Defective board	Replace the board
	Faulty harness	Check harness connections and integrity, replace if necessary.
Two or more motor start operating at the same time	Harness connection problems	Check harness connections and integrity, replace if necessary.
	Defective board	Replace the board
Double dispensing or jamming when DUO divider is installed	Badly installed divider	Adjust divider position
	Optical barriers not working	Check the optical barrier. Check harness of the optical barrier. Replace the optical barrier.
	Incorrect spiral step	Replace the spiral with a suitable step for the products on sale.
	Motor cam set to single vend	Rotate the cam on the motor.
The selection is not dispensed	Error message "Product xx"	Check the integrity of the wiring, connection with the motor of the wrong selection. Check motor and replace if necessary.



Only technicians from SandenVendo Europe or authorised personnel may carry out operations that require the machine's lower protection to be opened, because of possible risk of electric shocks and moving mechanical parts.

7 Out Of Order Operation

7.1 Disposal

Information about protecting the environment



Dispose of the packing in conformity with the recycling procedures.

In this way, you contribute towards reducing the need for virgin wood, using material that would otherwise accumulate at landfills.



Recycling the vending machine. Do not dispose the vending machine with other domestic waste. This vending machine contains electrical and electronic material, which, as indicated by **Directive ROHS 2011/65/UE**, and **Directive WEEE 2012/19/UE**, if treated correctly, can be salvaged and recycled at the end of its working life. Recycling this product contributes towards reducing the need for new materials and reducing the accumulation of waste.



ATTENTION: the manufacturer declines all responsibility for damage to the environment or for different systems that are used for the disposal of the materials that compose it.



To obtain updated information on treatment and recycling WEEE centers, please visit our website:

www.sandenvendo.com

7.2 Person in charge of disposal

Directive **WEEE** 2012/19/UE enforces the obligation **NOT** to dispose **WEEE** (Waste Electrical and Electronic Equipment) as household waste and to select this waste for separate collection.

By law, the person in charge of disposal must, upon receiving an appliance showing this



symbol , before disposing of it select the **WEEE** waste and make it available for collection.

7.3 Sanctions

The sanctions in case of the illegal DISPOSAL of **WEEE** waste are indicated in the national decrees related to the Directive **ROHS** 2011/65/UE, Directive **WEEE** 2012/19/UE.

Revision	Date	Change
0	20/05/2013	Manual Creation
1	06/10/2014	Updated
2	12/06/2015	Updated
3	15/12/2015	Updated
4	07/09/2016	Updated
5	21/12/2016	Updated
6	10/02/2017	Updated
7	24/03/2017	Updated
8	26/07/2017	Updated
9	07/09/2017	Updated
10	20/09/2017	Updated
11	05/12/2017	Updated
12	07/01/2019	Updated
13	31/05/2019	Updated
14	16/09/2019	Updated
15	15/01/2021	Updated all pages of the manual Added the Touchscreen models (STX, ST8 and ST6)
16	22/02/2021	Added Indication for Energy Consumption Category Updated Board List